

Standard EcoPower® Faucet

FEATURES

- Self-generating hydropowered EcoPower system
- No minimum daily usage requirement
- Micro-sensor positioned underneath the spout head for accurate hand detection ensuring smooth and consistent water distribution
- Vandal resistant aerator housing
- Durable chrome plated spout body
- Single-hole mount
- Kit includes spout body, controller box, and mounting hardware - less supply lines
- 0.35 gpm aerated flow
- Contributes to earning LEED® credits

MODELS

- TEL103-D20E**
 - TELS103 (Standard Spout)
 - TELC103-D20E (Controller: 0.11 gpc, 20 sec on-demand)
- TEL103-D20EM
 - **TEL103R-D20E** (Standard Spout Kit)
 - TLM10 (Mixing Valve)
- TEL103-D20ET**
 - TEL103-D20E (Standard Spout Kit)
 - TLT20 (Thermostatic Mixing Valve)

COLORS/FINISHES

- #CP Polished Chrome

OPTIONAL ACCESSORIES

- THP3158#CP - 4" Cover Plate
- THP3159#CP - 8" Cover Plate

PRODUCT SPECIFICATION

TOTO Model # _____ The faucet shall have hydropowered self-generating, EcoPower System. The faucet shall have maximum of 20 seconds on-demand flow (0.11gpc). The faucet shall have self-adjusting sensor. Product equipped with 0.35gpm flow regulator.



CODES/STANDARDS

- Operates below federally mandated consumption limit of 0.25gpc
- Complies to California Green Building Code, CALGreen of 0.20 gpc
- Meets or exceeds ASME A112.18.1M/CSA B125.1, and NSF372-2011
- Certifications: IAPMO(cUPC), State of Massachusetts, and others
- California Green Code and City of Los Angeles Water Efficiency Ordinance
- ADA compliant
- Complies with federal and state statutes as low-lead (contains a weighted average of 0.25% lead or less)

For codes and standards of mixing valves TLM10, please refer to corresponding product spec sheet.



TEL103 Series

Standard EcoPower® Faucet

SPECIFICATIONS

Power Supply	Ecopower
Sensor Detection Range	5-1/8" - 7-7/8" (130 - 200mm) Sensor is self-adjusting
Water Supply Pressure	Min (Dynamic/Flowing) Pressure: 15 psi (100kPa) Max (Static) Pressure: 80 psi (551kPa)
Water Supply	G1/2 (1/2 NPSM compatible)
Inlet Temperature Range	32-110°F(0-42°C)
Ambient Temperature	32-104°F(0-40°C)
Humidity	Max. 90% RH
Flow Rate	0.11 gpc* - max 20 second On-Demand** (0.11 gpc = 0.35 gpm x 20/60 sec) Equipped with 0.35 gpm flow control
Warranty	Three years

NOTE

Following the federal mandate for water efficiency outlined in the Environmental Protection Act of 1992, faucets can be rated for water consumption based on two categories: Flow Rate and Water Consumption. TOTO uses the water consumption standard because it is the most accurate method of measuring water use. TOTO faucets also comply with the CALGreen Guideline of water usage.

Water Saving

On-Demand [20 sec.] faucet (0.11gpc)
Federal Standard (0.25gpc) -56% less
CAL Green (0.20gpc) -45% less

*Gallons per cycle (gpc) is the amount of water per usage cycle .

**On-demand refers to the way in which the water is dispersed (i.e.; water is only dispersed when the sensor is activated by the user as needed).

Standard

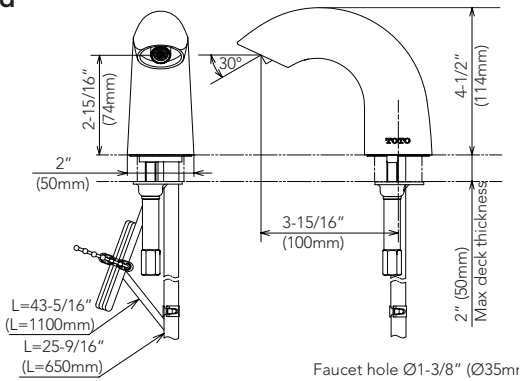

Controller

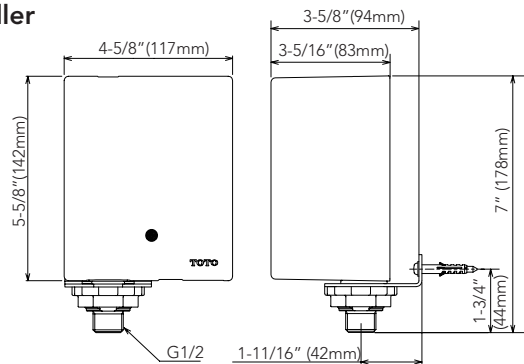

Available Mixing Valves

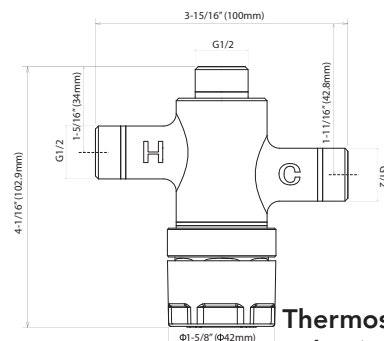
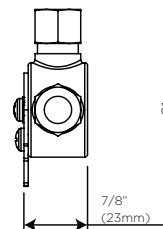
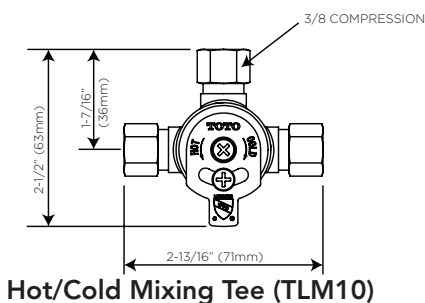

G1/2 compatible with 1/2 NPSM

TOTO

These dimensions and specifications are subject to change without notice

Ph: (888) 295-8134 | Fax: (800) 699-4889 | www.totousa.com | © TOTO USA

#SS-01217 v.04

Pending release date: Fall 2017