

Product

90 deg. Appliance Stub Out for Use with TracPipe and CounterStrike

Project Information

Job Name:	Date Submitted:
Location:	Submitted By:
Engineer:	Approved By:
Contractor:	Manufacturer's Rep:

Installation

Must be installed in accordance with the TracPipe Design Guide and Installation Instructions and all applicable codes

Application Information

Schedule 40 B.I.P. 90 deg. stub out for use at movable appliance locations, with mounting plate

Technical Data

Materials

Schedule 40 B.I.P.
Mounting Plate 12 Ga. Carbon Steel

Pressure Ratings (used with tubing)

Specification Operating Pressure	25 PSIG
CSA International Evaluation Report - Max Operating Pressure, 3/8" through 1-1/4"	125 PSIG

Temperature Ratings (used with tubing)

Operating Temperature Range	-20 to 200 Deg F
-----------------------------	------------------

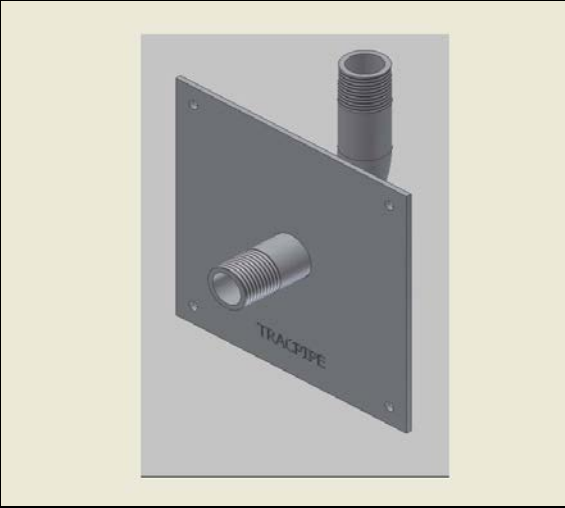

Codes

Standards

NPT Thread per ANSI B1.20.1

Listings

Dimensional Information

✓	Size	P/N	Mounting Flange Dim (Nom)	Fitting length (Nom. in.)	TracPipe or CounterStrike Size	Weight (lbs)
<input type="checkbox"/>	1/2"	FGP-ASP90S-500	5" x 5"	1-1/2"	1/2"	0.95
<input type="checkbox"/>	3/4"	FGP-ASP90S-750	5" x 5"	1-1/2"	3/4"	1.25