

THE POWER OF  
**REDARC**®

# 6A In-Vehicle 3-Stage 12V Battery Charger

**BCDC1206**

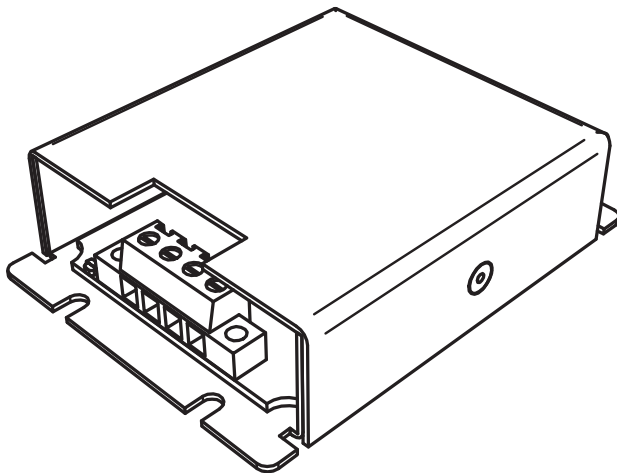

# THE BCDC1206

The BCDC1206 is a three stage 12V DC-DC battery charger that operates with an input of between 9 and 32V. The input voltage of the BCDC1206 can be above, below or equal to the output voltage making it ideal for charging an auxiliary 12V battery where the distance from the main battery may cause a significant voltage drop. The wide operating voltage range provides a simple solution to charging trailer mounted batteries. The BCDC1206 can deliver sufficient current to charge a battery that has a typical DC compressor fridge connected.

When the BCDC1206 is turned on it will start in Boost mode, Boost mode maintains a constant current until the battery voltage reaches 14.5V. The charger will then move to Absorption mode, maintaining the voltage at this level for a predetermined period of time; after which it will enter Float mode. Float mode maintains 13.7V on the battery being charged until a load on the battery causes the battery voltage to drop below 12.2V when it then re-enters Boost mode.

## FEATURES

- Fully encapsulated electronics
- Compact in size
- Over current and short circuit protection
- High operating temperature range up to 70°C
- Over temperature protection
- Input under and over voltage shutdown
- Protected against reverse polarity power connection to input and output by external fuses (Fuses required 10A on input and output, not supplied)
- Led indication of charge stage:  
20 Flashes per second = Boost, 4 Flashes per second = Absorption, ON Solid = Float

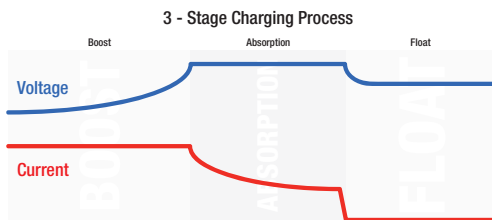

## CONNECTIONS AND DIMENSIONS

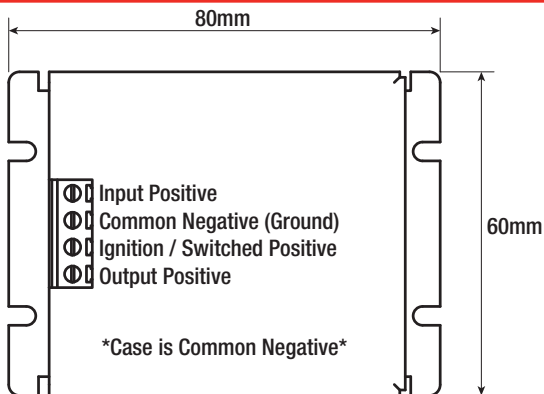

# SPECIFICATION

|  |                                 |
|--|---------------------------------|
| I/P Voltage Range                      | 9-32VDC                         |
| Absorption Voltage                     | 14.5V                           |
| Float Voltage                          | 13.7V                           |
| Boost commencement Voltage             | 12.2V                           |
| Current Limit (I/P Voltage Dependent)* | 3.5 ~ 6.5A                      |
| Efficiency At Rated Load (Typical)     | > 90%                           |
| No Load Current (Ignition ON)          | <100mA                          |
| Standby Current (Ignition OFF)         | 150µA                           |
| Recommended I/P Fuse (Not Supplied)    | 10A                             |
| Recommended O/P Fuse (Not Supplied)    | 10A                             |
| Operating Temperature (100% load)      | -20°C ~ 50°C                    |
| Standards                              | UNECE Regulation 10: revision 5 |

\*Output current does vary with changes in input voltage. Contact REDARC if more information is required.

# INSTALLATION

- The unit should be mounted in a cool, dry location as close as possible to the battery under charge.
- To minimise voltage drop, ensure all additional wiring, especially from supply, is of adequate thickness.
- Appropriate sized fuses must be used to protect the unit from reverse polarity connections; without said fuses, the unit will be damaged in the event of a reverse polarity connection.
- The ignition connection is supplied to allow the unit to be switched by a low current positive source of between 9 and 32V.
- For continuous operation, the ignition input can be connected directly to the supply input.
- If screw terminals are likely to be subjected to moisture, apply an anti-corrosive coating to the terminal block.

# WIRING

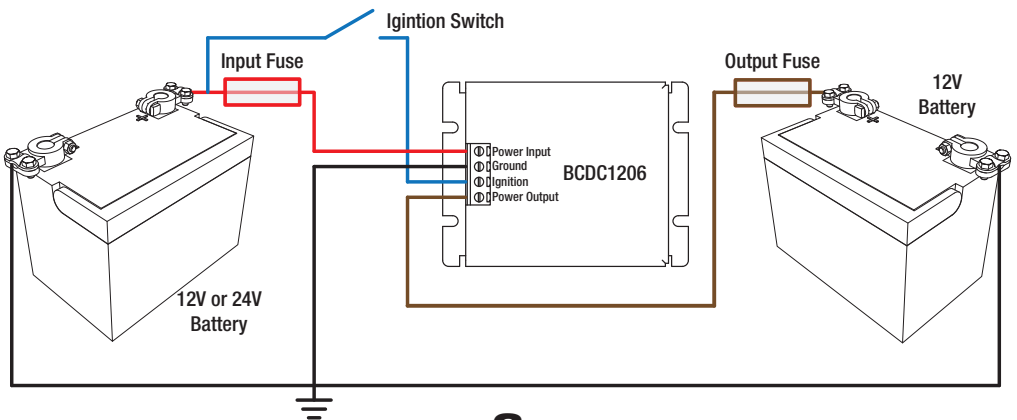

# TWO YEAR PRODUCT WARRANTY

Over the last three decades our company has established a reputation as the power conversion specialist.

A 100% Australian-owned company, we have met the needs of customers in transport and other industries through exciting, innovative thinking.

We believe in total customer satisfaction and practice this by offering our customers:

- Technical advice free of jargon and free of charge
- Prompt turnaround of orders throughout Australia and globally
- Friendly, personalised, professional service and product support

In the unlikely event that a technical issue arises with a REDARC product, customers are encouraged to initially contact the REDARC Technical Support Team on (08) 8322 4848 or [power@redarc.com.au](mailto:power@redarc.com.au) for prompt and efficient diagnosis and product support.

Our goods come with guarantees that cannot be excluded under the Australian Consumer Law. You are entitled to a replacement or refund for a major failure and compensation for any other reasonably foreseeable loss or damage. You are also entitled to have the goods repaired or replaced if the goods fail to be of acceptable quality and the failure does not amount to a major failure.

The benefits of this Warranty are in addition to other rights and remedies available at law in respect of the Products and shall not derogate from any applicable mandatory statutory provisions or rights under the Australian Consumer Law.

REDARC Electronics Pty Ltd as the REDARC Trust trading as REDARC Electronics ("REDARC") offers a warranty in respect of its Products where the Products are purchased from an authorised distributor or reseller of REDARC by a person ("Purchaser"), on the terms and conditions, and for the duration, outlined below in this document ("Warranty").

1. In this Warranty, the term **Products** means:

- 1.1 all products manufactured or supplied by REDARC (excluding its solar products which are covered by REDARC's Solar Product Warranty); and
- 1.2 any component of or accessory for any product in clause 1.1 manufactured or supplied by REDARC.

**Offer and duration of product warranties**

2. REDARC warrants that its Products will be free, under normal application, installation, use and service conditions, from defects in materials and workmanship affecting normal use, for **2 years** from the date of purchase (**Warranty Period**).
3. Where a Product malfunctions or becomes inoperative during the Warranty Period, due to a defect in materials or workmanship, as determined by REDARC, then subject to further rights conferred by the Australian Consumer Law on the Purchaser, REDARC will, in exercise of its sole discretion, either:
  - 3.1 repair the defective Product;
  - 3.2 replace the defective Product; or
  - 3.3 provide a refund to the Purchaser for the purchase price paid for the defective Product, without charge to the Purchaser.
4. The warranty given by REDARC in clause 3 covers the reasonable costs of delivery and installation of any repaired or replaced Products or components of Products to the Purchaser's usual residential address notified to REDARC, together with the reasonable costs of removal and return of any Products determined by REDARC to be defective.
5. If the Purchaser incurs expenses of the nature referred to in clause 4 in the context of making a claim pursuant to this Warranty that is accepted by REDARC, the Purchaser will be entitled to claim for reimbursement of those expenses which REDARC determines, in exercise of its sole discretion, to be reasonably incurred, provided that the claim is notified to REDARC in writing at the postal address or email address specified in clause 21 and includes:
  - 5.1 details of the relevant expenses incurred by the Purchaser; and
  - 5.2 proof of the relevant expenses having been incurred by the Purchaser.

**Exclusions and limitations**

6. This Warranty will not apply to, or include any defect, damage, fault, failure or malfunction of a Product, which REDARC determines, in exercise of its sole discretion, to be due to:
  - 6.1 normal wear and tear or exposure to weather conditions over time;
  - 6.2 accident, misuse, abuse, negligence, vandalism, alteration or modification;
  - 6.3 non-observance of any of the instructions supplied by REDARC, including instructions concerning installation, configuring, connecting, commissioning, use or application of the Product, including without limitation choice of location;
  - 6.4 failure to ensure proper maintenance of the Product strictly in accordance with REDARC's instructions or failure to ensure proper maintenance of any associated equipment or machinery;
  - 6.5 repairs to the Product that are not strictly in accordance with REDARC's instructions;
  - 6.6 installation, repairs or maintenance of the Product by, or under the supervision of, a person who is not a qualified auto electrician or technician, or if non-genuine or non-approved parts have been fitted;
  - 6.7 faulty power supply, power failure, electrical spikes or surges, lightning, flood, storm, hail, extreme heat, fire or other occurrence outside the control of REDARC;
  - 6.8 use other than for any reasonable purpose for which the Product was manufactured;
  - 6.9 any indirect or incidental damage of whatever nature outside the control of REDARC.
7. Warranty claims in respect of a Product must be made in writing to REDARC at the postal address or email address specified in clause 21 within the Warranty Period. Such claims must include the following:
  - 7.1 details of the alleged defect or fault and the circumstances surrounding the defect or fault;
  - 7.2 evidence of the claim, including photographs of the Product (where the subject of the claim is capable of being photographed);
  - 7.3 the serial number of the Product, specified on the label affixed to the Product; and
  - 7.4 proof of purchase documentation for the Product from an authorised distributor or reseller of REDARC, which clearly shows the date and place of purchase.The return of any Products without the prior written instructions of REDARC will not be accepted by REDARC.

8. Without limiting any other clause in this Warranty, REDARC has the right to reject any Warranty claim made by a Purchaser pursuant to this Warranty where:

- 8.1 The Purchaser does not notify REDARC in writing of a Warranty claim within the Warranty Period;
  - 8.2 the Purchaser does not notify REDARC in writing of a Warranty claim within 1 month of becoming aware of the relevant circumstances giving rise to the claim, so that any further problems with the Product are minimised;
  - 8.3 the serial number of the Product has been altered, removed or made illegible without the written authority of REDARC;
  - 8.4 the Purchaser is unable to provide proof of purchase documentation in accordance with clause 7.4 or evidence that the Product was properly installed and removed (if relevant), and that proper maintenance has been performed on the Product, by, or under the supervision of, a qualified auto electrician or technician, in accordance with the instructions of REDARC.
9. If the Product is found to be working satisfactorily on return to REDARC or upon investigation by REDARC, the Purchaser must pay REDARC's reasonable costs of testing and investigating the Product in addition to shipping and transportation charges. Where REDARC is in possession of the Product, the Product will be returned to the Purchaser on receipt of the amount charged.
  10. Any replaced Products or components of Products shall become the property of REDARC.
  11. REDARC may, in exercise of its sole discretion, deliver another type of Product or component of a Product (different in size, colour, shape, weight, brand and/or other specifications) in fulfilling its obligations under this Warranty, in the event that REDARC has discontinued manufacturing or supplying the relevant Product or component at the time of the Warranty claim, or where such Product or component is superior to that originally purchased by the Purchaser.

**Other conditions of Warranty**

12. If the Purchaser acquired a Product for the purpose of resupply, then this Warranty shall not apply to that Product.
13. In particular, the sale of a Product via an online auction, online store or other internet website by a party that is not an authorised distributor or reseller of the Product will be deemed to be a resupply within the meaning of the Australian Consumer Law and will render this Warranty void, as REDARC has no control over the storage, handling, quality or safety of Products sold by such persons.
14. A Purchaser shall only be entitled to the benefit of this Warranty after all amounts owing in respect of the Product have been paid.
15. While REDARC warrants that the Products will be free from defects in materials and workmanship in the circumstances set out in this Warranty, to the maximum extent permitted by law REDARC does not warrant that the operation of the Products will be uninterrupted or error-free.
16. To the maximum extent permitted by law, REDARC's determination of the existence of any defect and the cause of any defect will be conclusive.
17. Spare parts or materials for the Products are guaranteed to be available for a period of at least 2 years after purchase of the Products.
18. The agents, officers and employees of any distributor or reseller of the Products and of REDARC are not authorised to vary or extend the terms of this Warranty.
19. REDARC shall not be responsible or liable to the Customer or any third party in connection with any non-performance or delay in performance of any terms and conditions of this Warranty, due to acts of God, war, riots, strikes, warlike conditions, plague or other epidemic, fire, flood, blizzard, hurricane, changes of public policies, terrorism and other events which are beyond the control of REDARC. In such circumstances, REDARC may suspend performance of this Warranty without liability for the period of the delay reasonably attributable to such causes.
20. If a clause or part of a clause in this Warranty can be read in a way that makes it illegal, unenforceable or invalid, but can also be read in a way that makes it legal, enforceable and valid, it must be read in the latter way. If any clause or part of a clause in this Warranty is illegal, unenforceable or invalid, that clause or part is to be treated as removed from this Warranty, but the rest of this Warranty is not affected.

**REDARC's contact details**

21. REDARC's contact details for the sending of Warranty claims under this Warranty are:

REDARC Electronics Pty Ltd  
23 Brodie Road (North), Lonsdale SA 5160  
Email: [power@redarc.com.au](mailto:power@redarc.com.au)  
Telephone: +61 8 8322 4848