

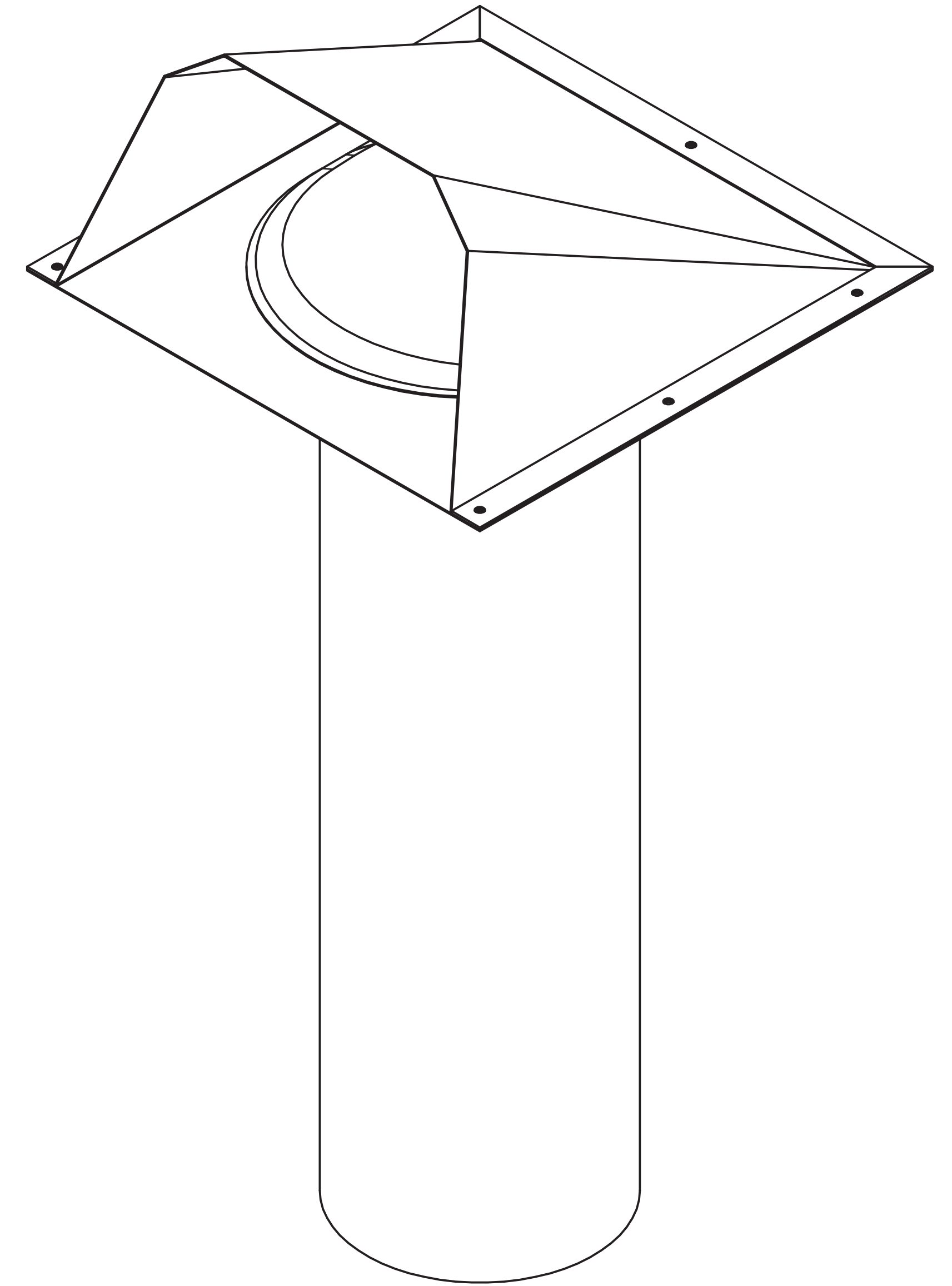

SECTION A-A

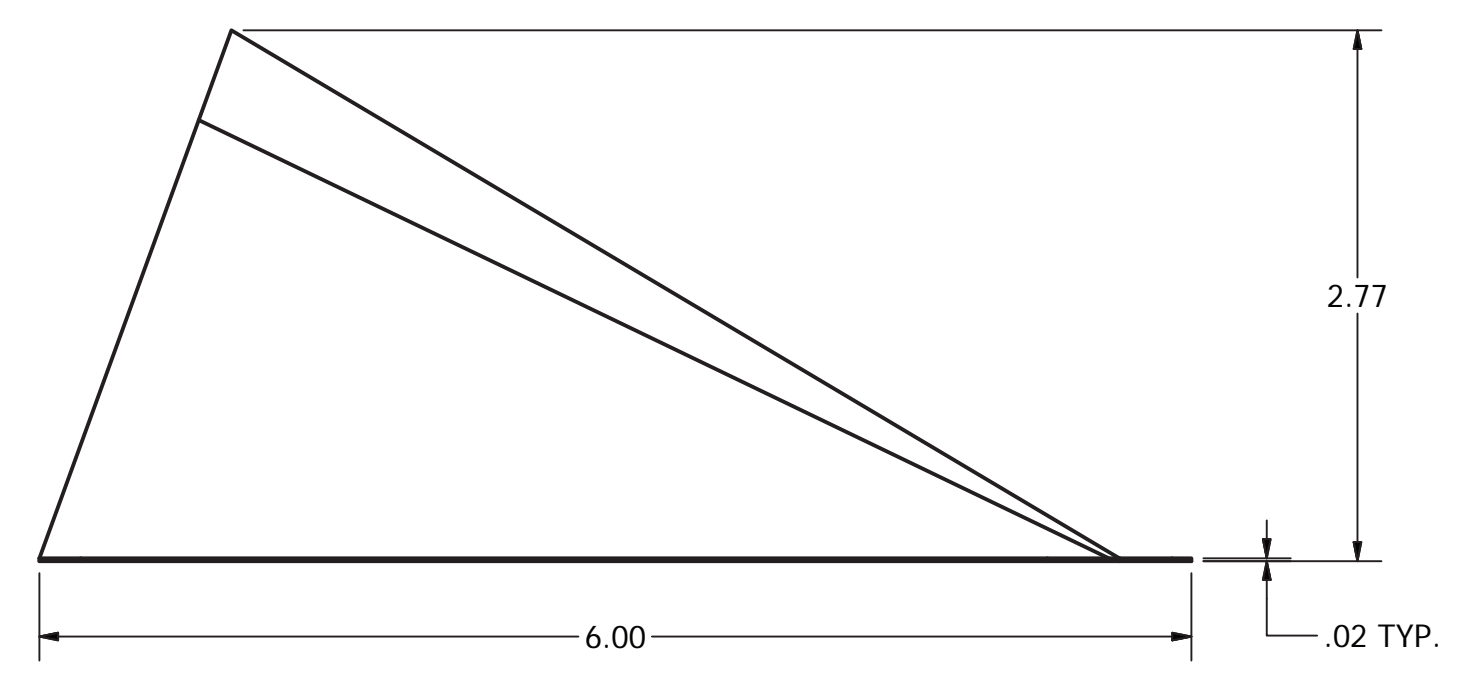

DRAWN BY J. VALENTI		2/12/2017		LAMBRO INDUSTRIES, INC.	
SIZE D	DWG NO 543 ASSEMBLY		REV A		
NOT TO SCALE			SHEET 1 OF 1		

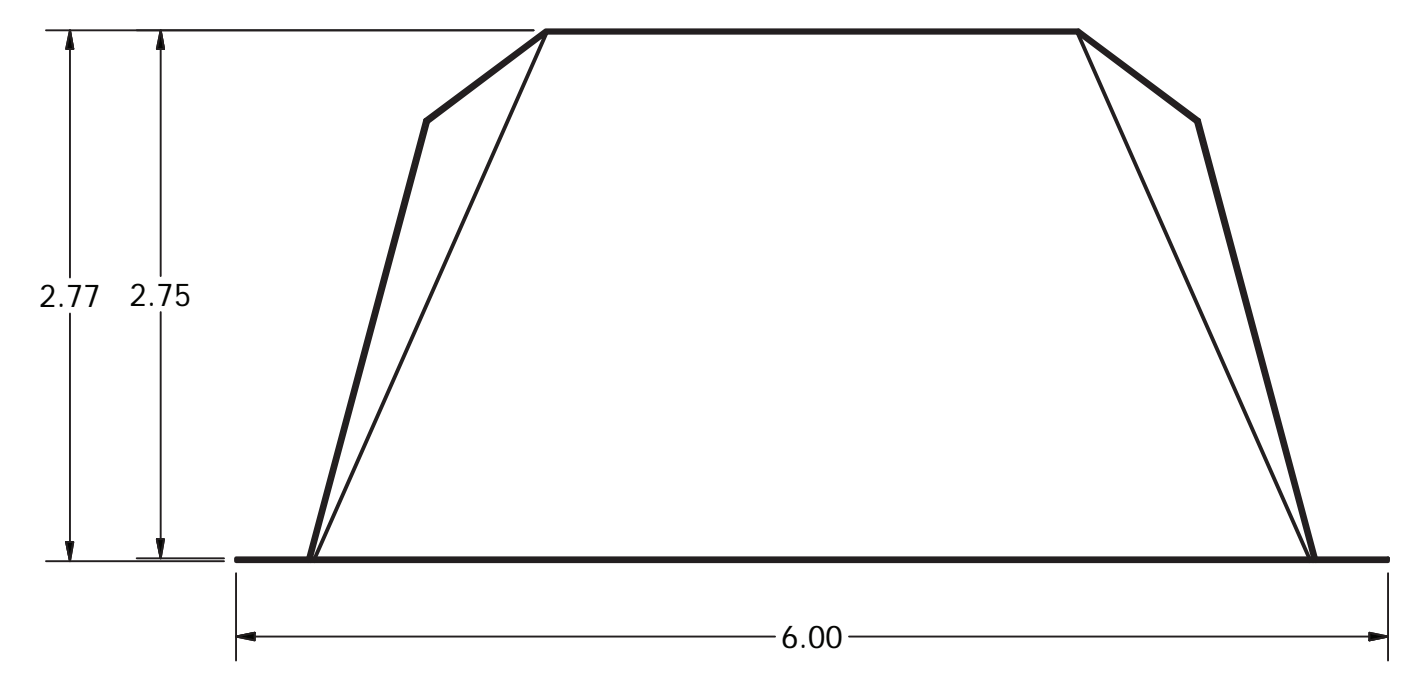
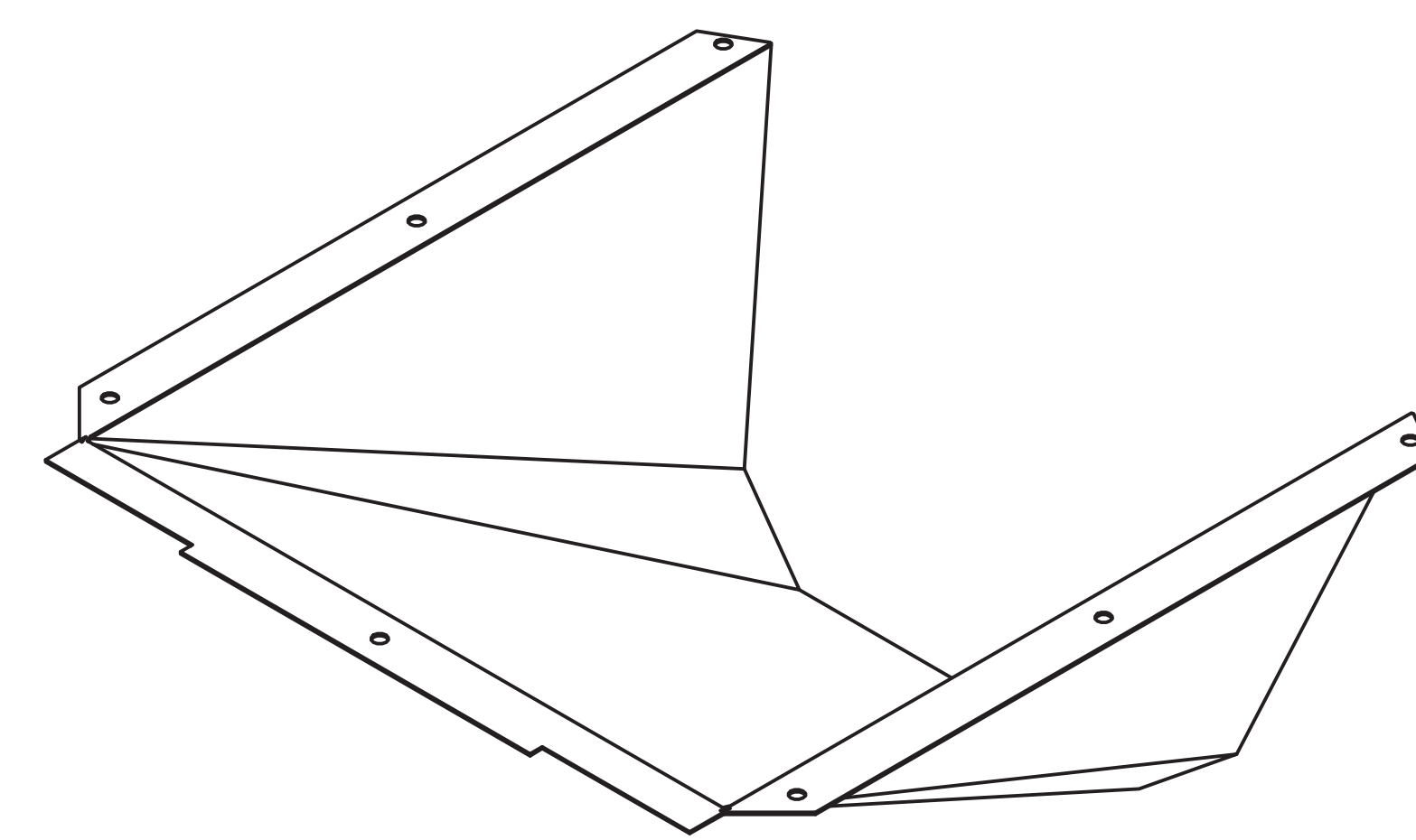
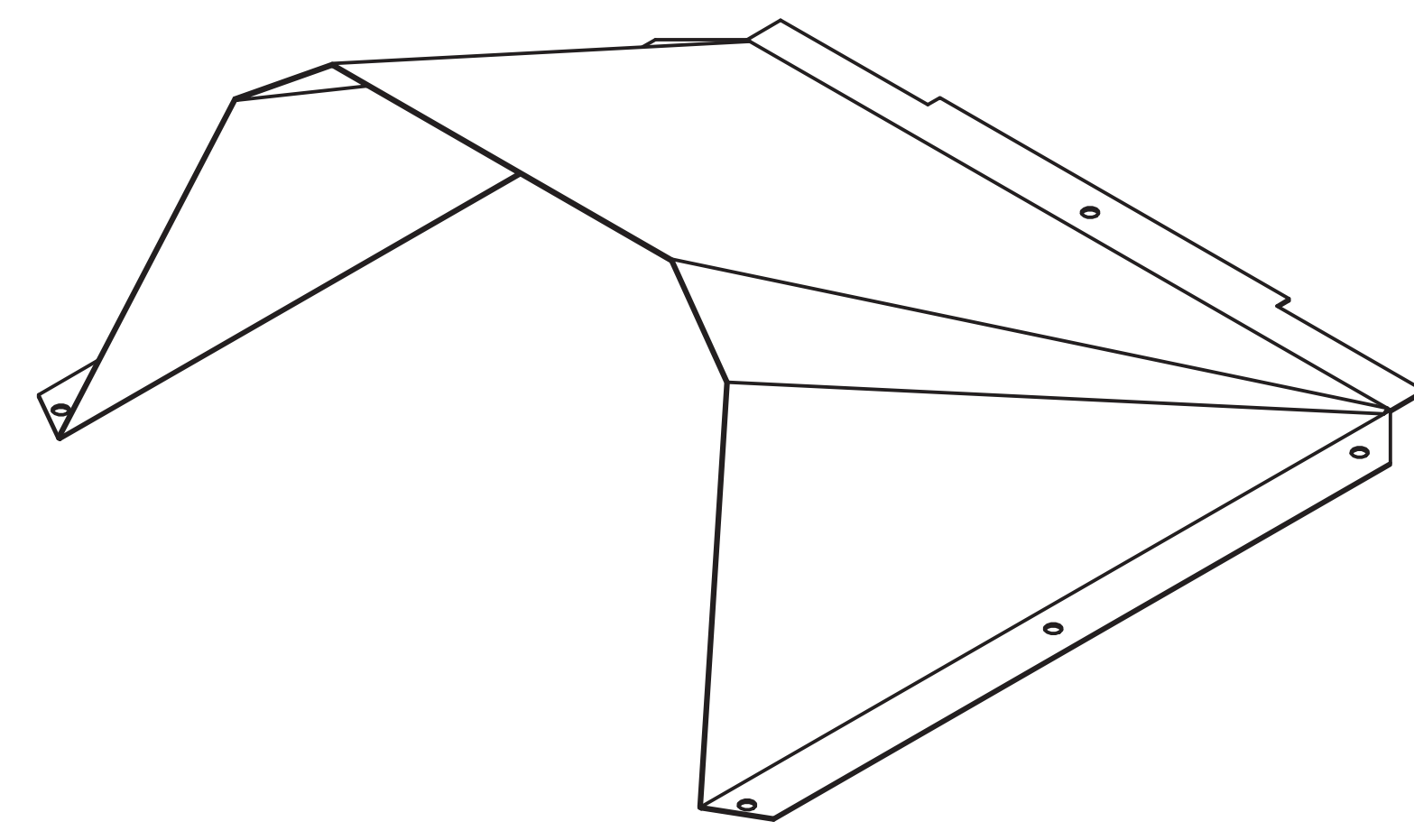
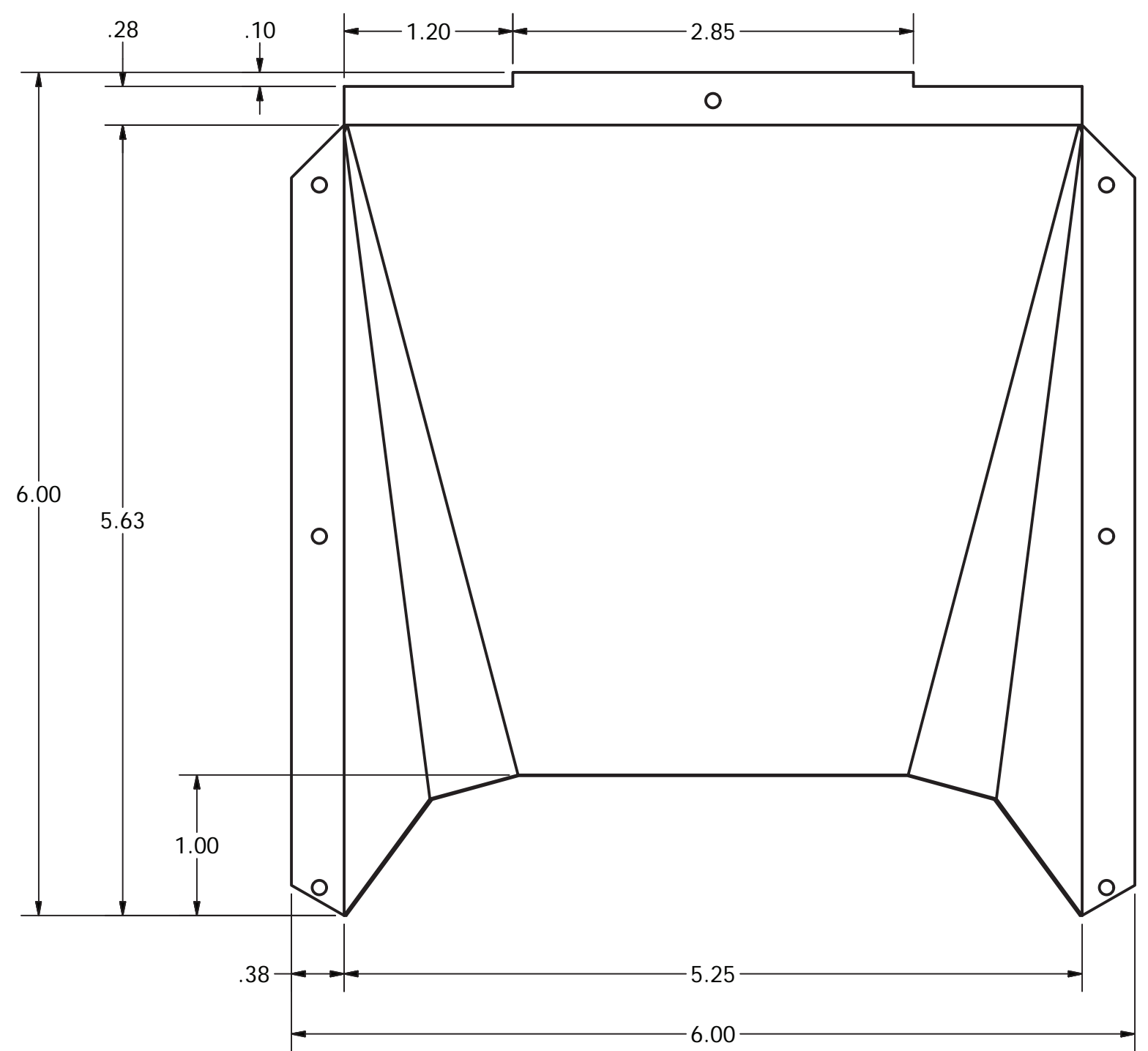

DRAWN BY J. VALENTI		2/12/2017		LAMBRO INDUSTRIES, INC.	
					
SIZE D	DWG NO 543 CAP		REV A		
NOT TO SCALE			SHEET 1 OF 1		

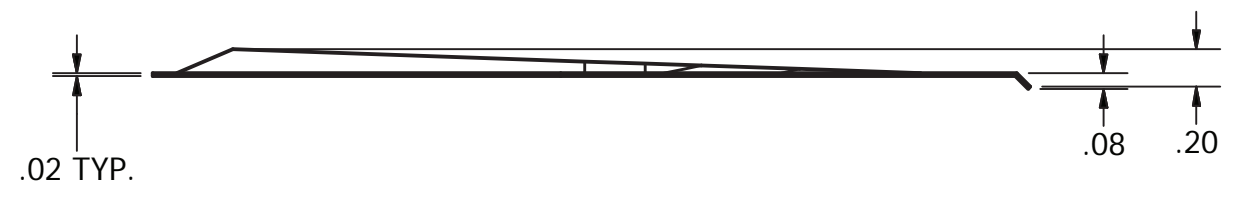
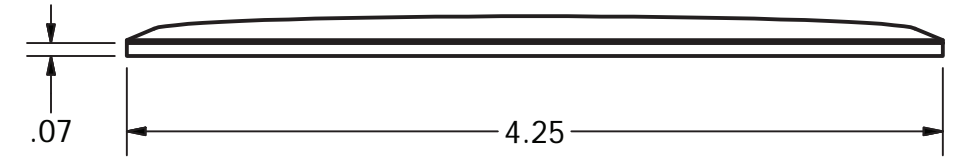
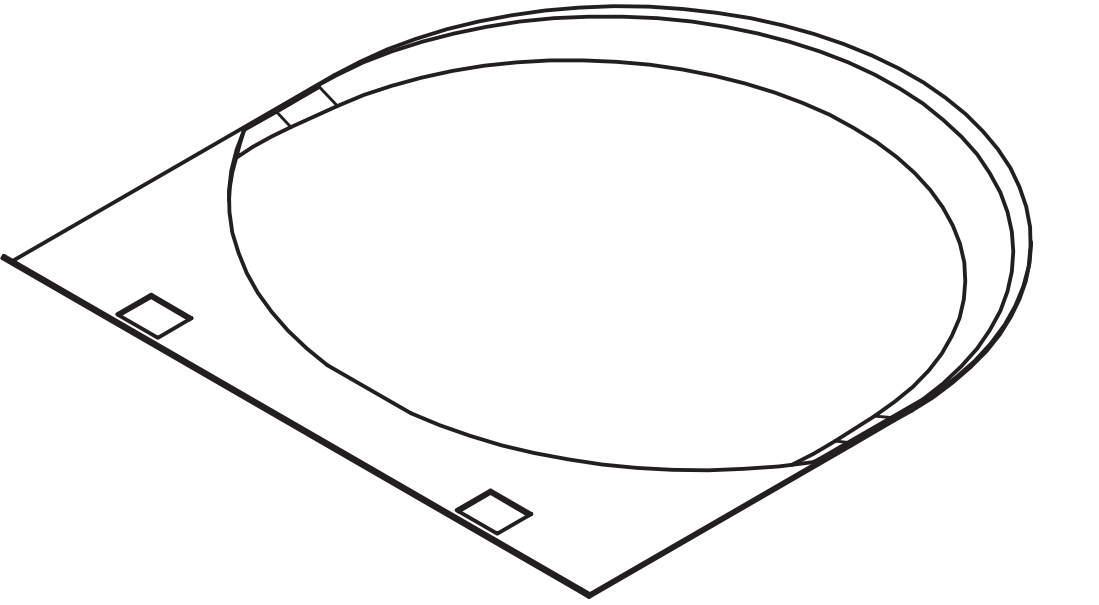
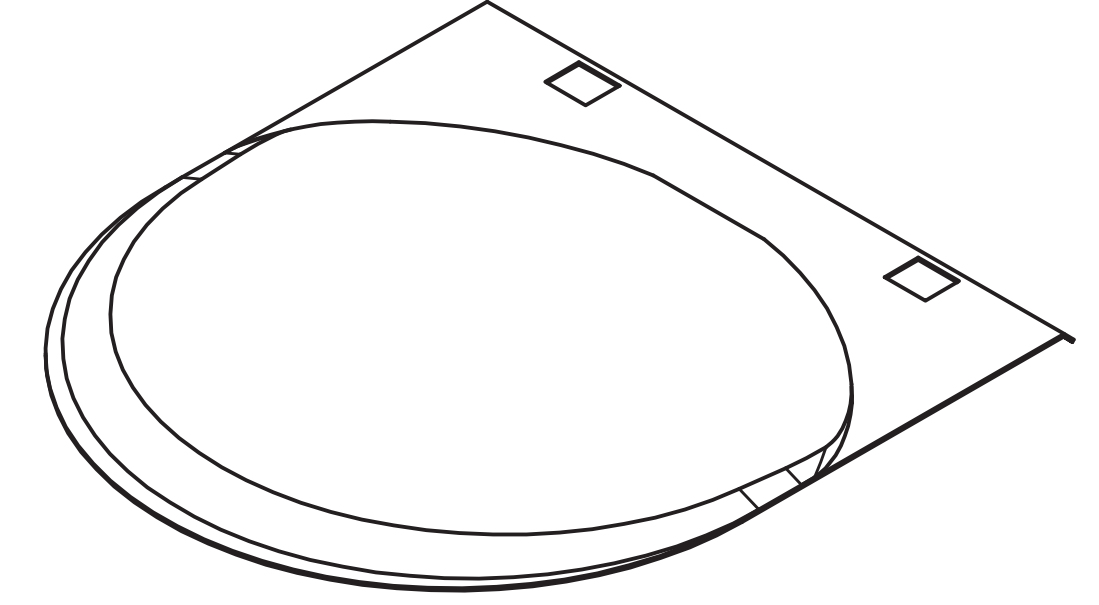
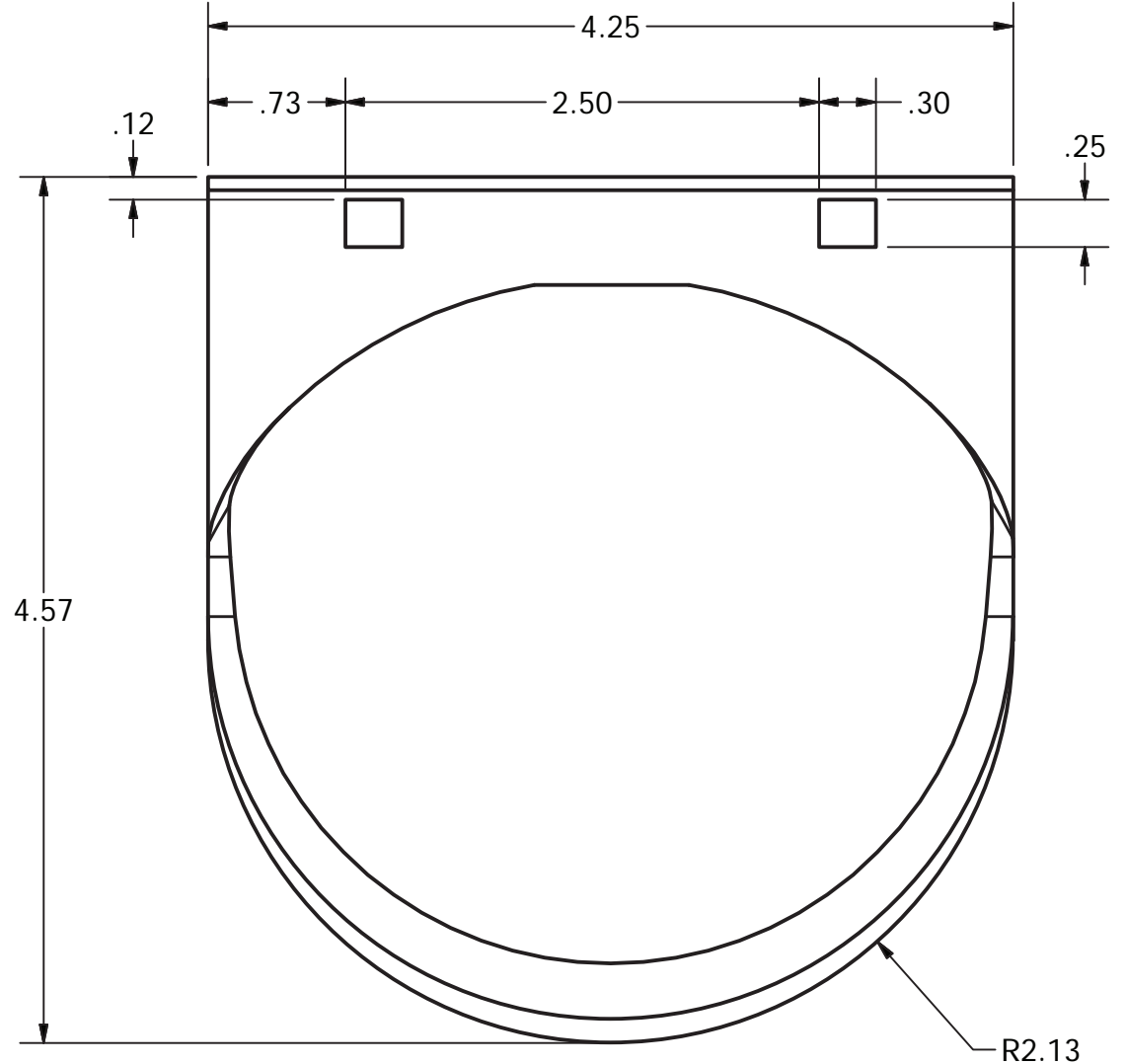

DRAWN BY
J. VALENTI

2/12/2017

LAMBRO INDUSTRIES, INC.



TITLE			
543 FLAP			
SIZE	DWG NO	REV	
C	543 FLAP	A	
NOT TO SCALE	SHEET 1 OF 1		

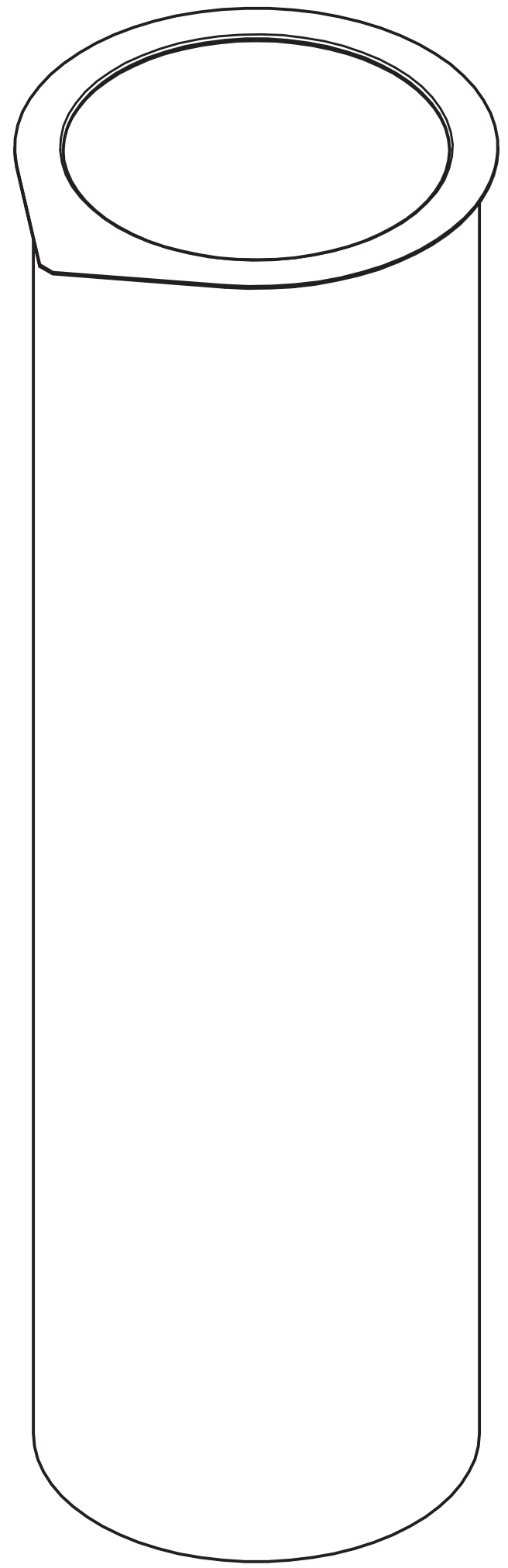
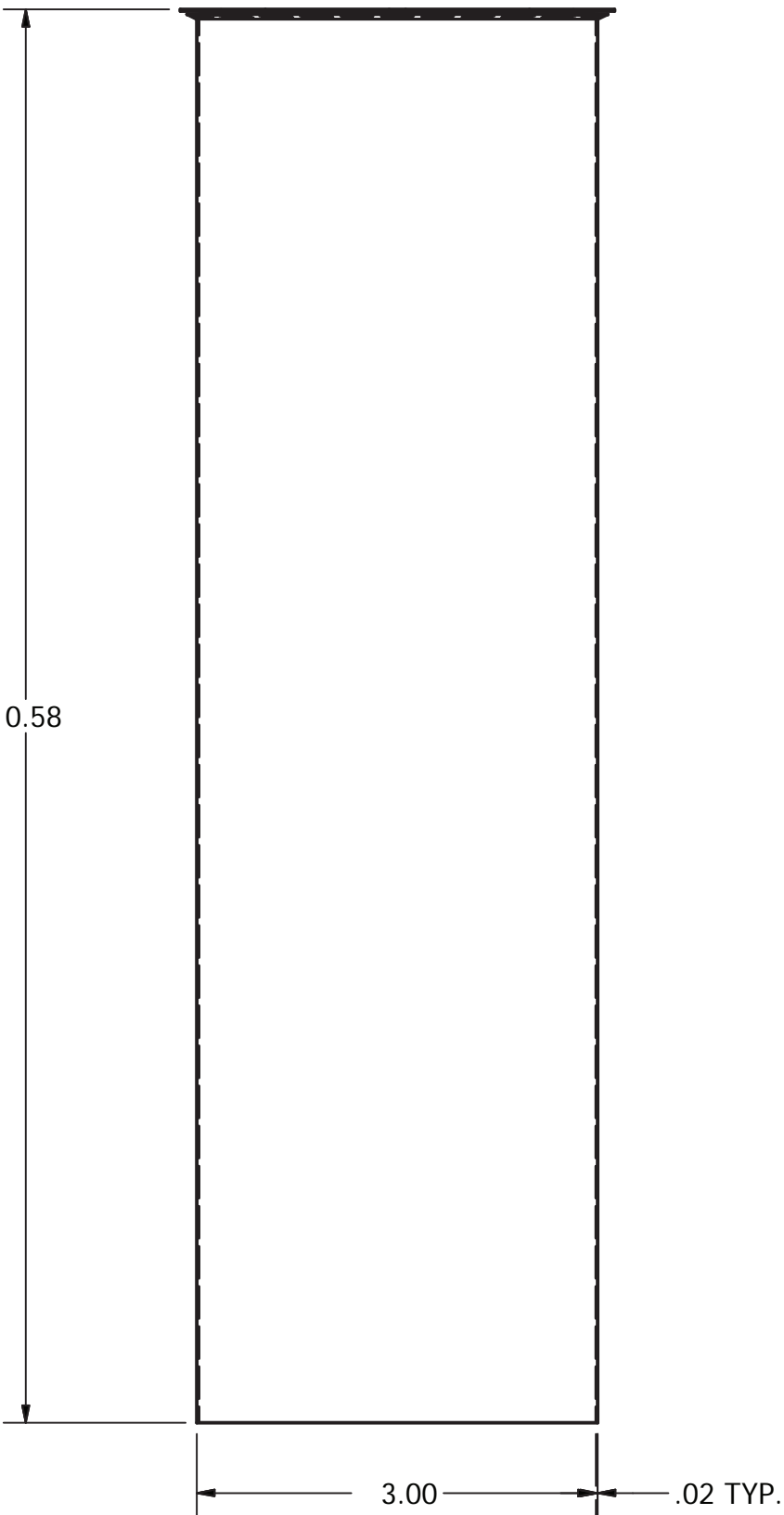
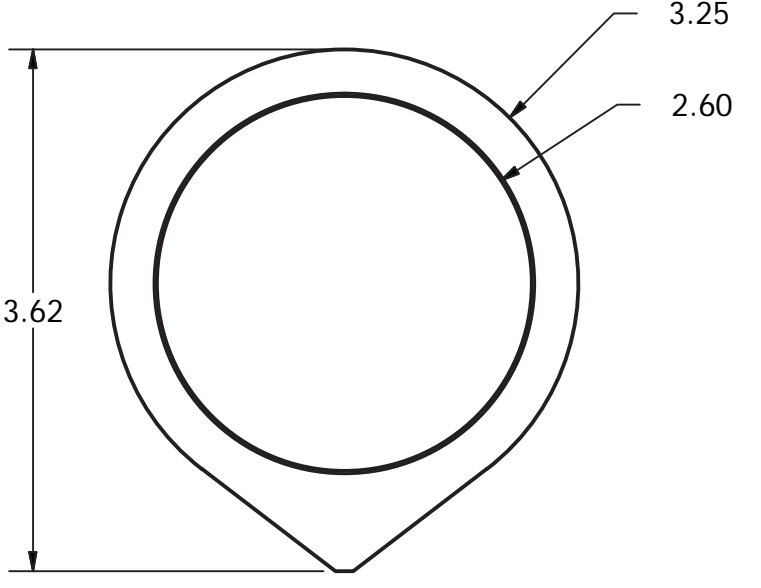
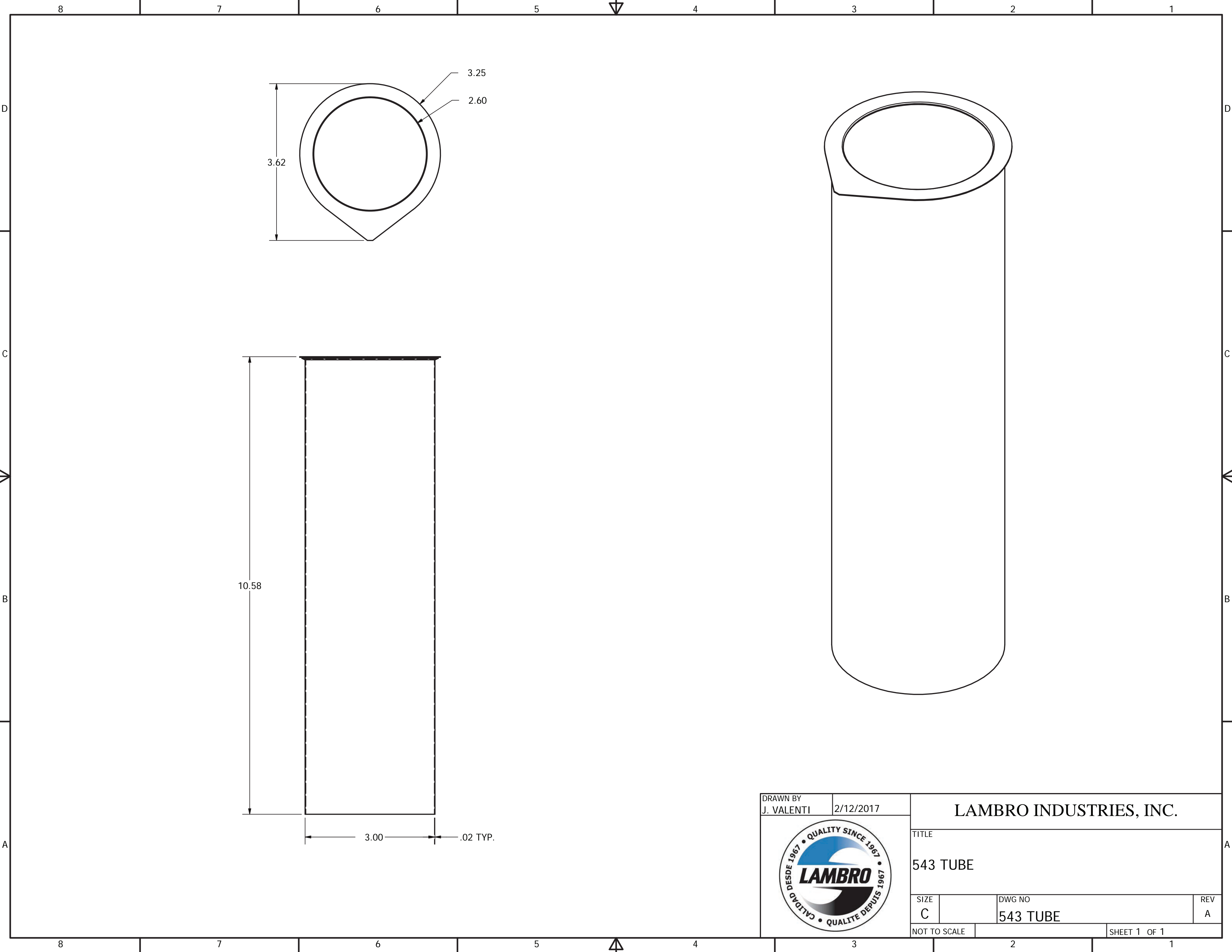

DRAWN BY J. VALENTI		2/12/2017		LAMBRO INDUSTRIES, INC.	
					
SIZE	DWG NO		REV		
C	543 TUBE		A		
NOT TO SCALE			SHEET 1 OF 1		

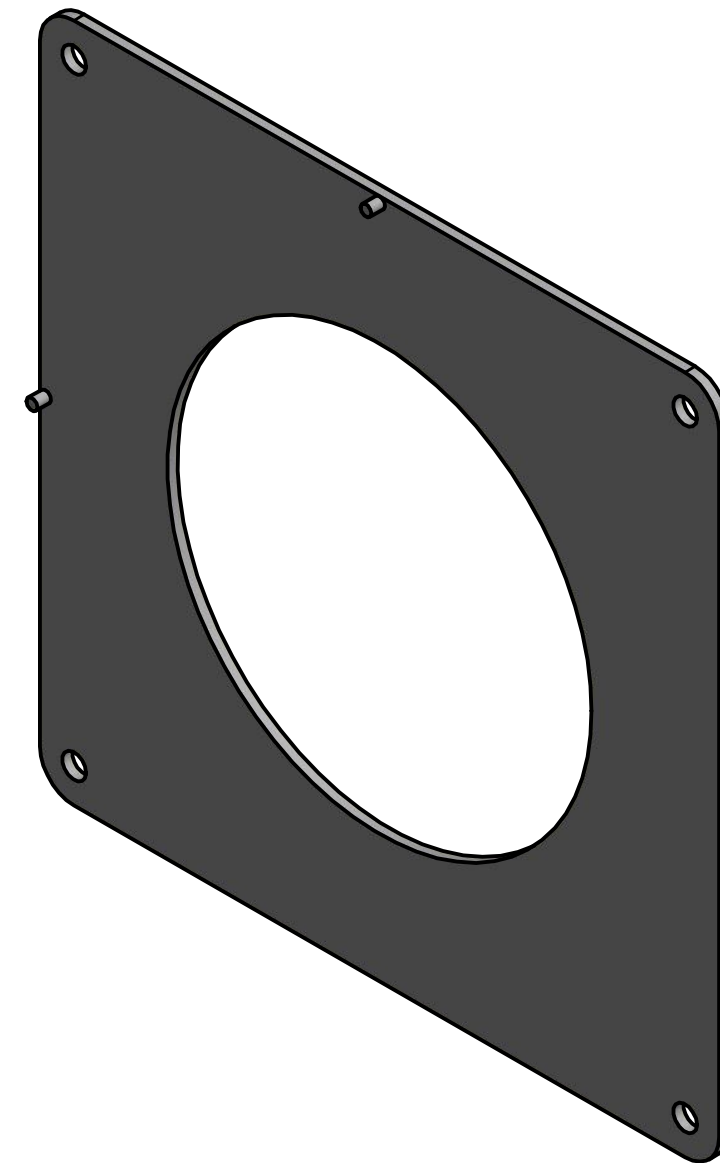
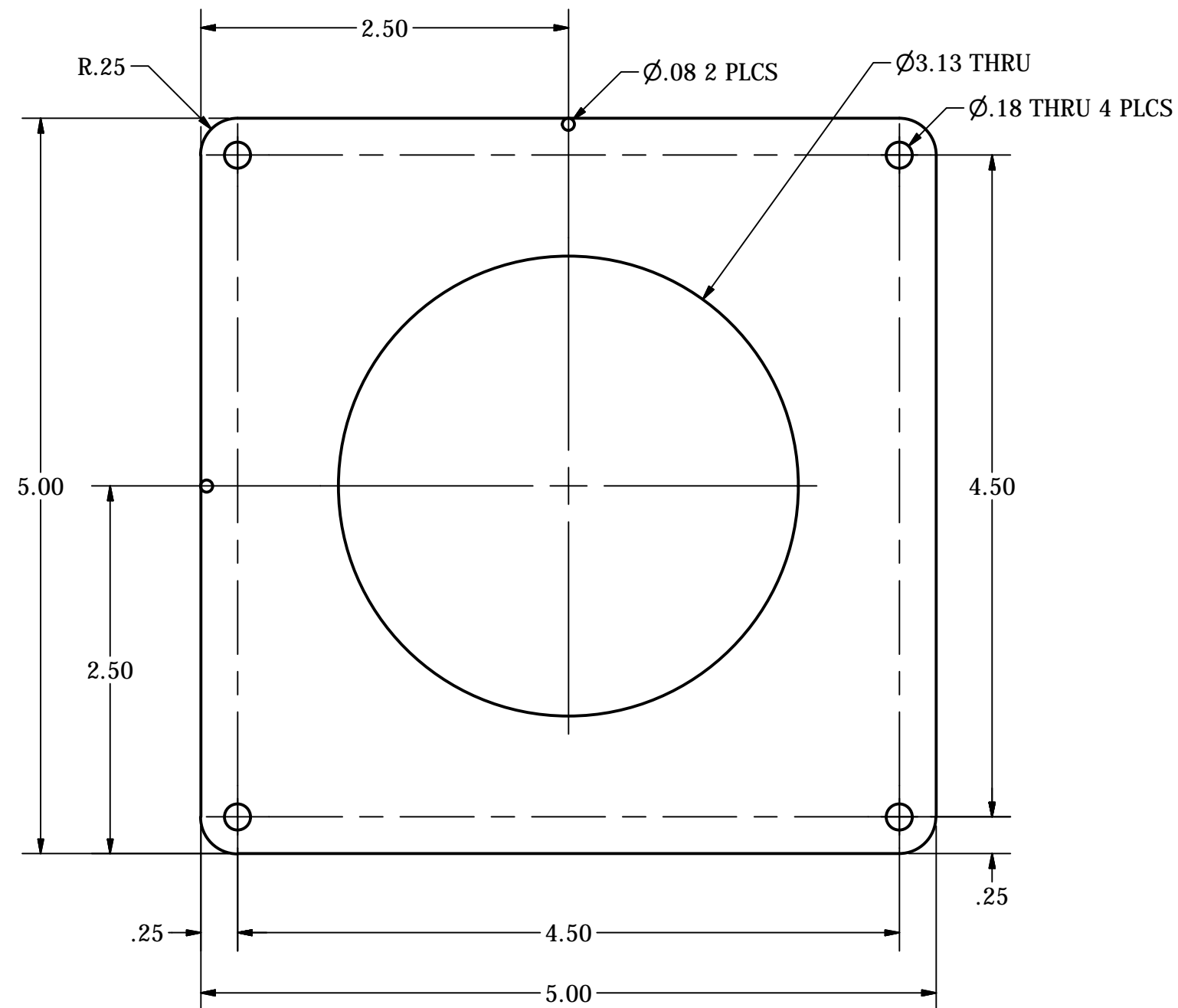
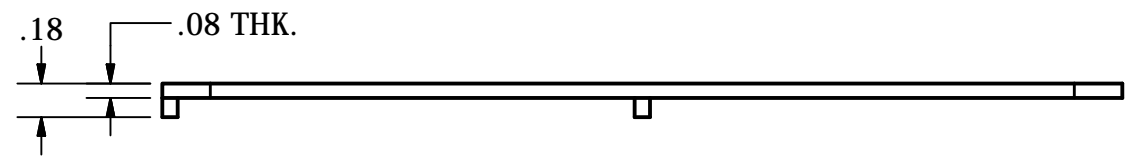

DRAWN J. VALENTI	4/5/2015	LAMBRO INDUSTRIES, INC.		
CHECKED		TITLE		
QA		222W DUCT SUPPORT PLATE		
MFG		SIZE C	DWG NO 222W	REV A
APPROVED		SCALE	SHEET 1 OF 1	