

### Power connection for H311, H611, and H621

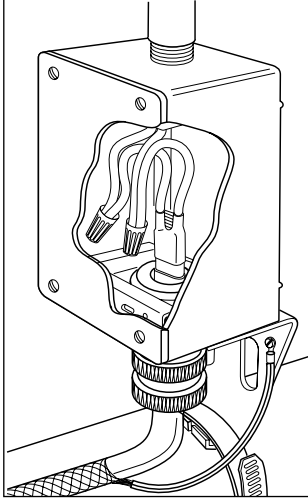

### Power connection for H612 and H622

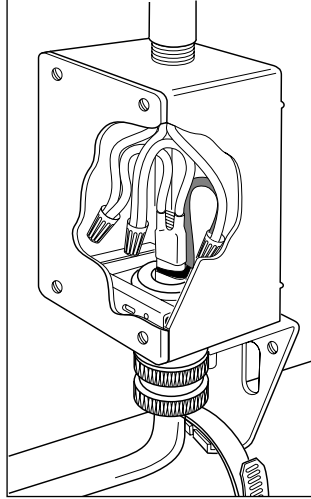

## Installation Instructions

### Description

The WinterGard power connection kit is for use only with the following WinterGard heating cables: H311, H611, H612, H621, and H622.

Materials for one power connection and one end seal are included. All WinterGard heating cables are designed for water-pipe freeze protection applications. Only the H612 and H622 cables can be used for both pipe freeze protection and roof and gutter de-icing applications. Do not use this kit with aluminum feed wires. For additional technical support call Tyco Thermal Controls at (800) 545-6258.

**Note:** For WinterGard heating cables in pipe heating applications, refer to pages 2-4. For WinterGard Wet heating cables H612 and H622 in roof and gutter de-icing applications, refer to pages 5-7.

### Tools Required

- Needle nose pliers
- Diagonal cutters
- Adjustable wrench
- Pen
- Utility knife
- Screwdriver
- Propane torch or heat gun
- Panduit CT100 crimp tool

### Additional Materials Required

- UL Listed or CSA Certified junction box suitable for the location, with a clearance hole for 1/2-inch conduit or 1/2-inch NPT threaded hub.
- For H311, H611, and H621, you must use a metallic junction box to ensure proper grounding.
- Your application may require additional WinterGard accessories; for example, H903 application tape for pipe applications; H913/H914 roof clips and/or H915 downspout hangers for roof and gutter de-icing applications.

### Approvals



718K Pipe Heating Cable,  
or 877Z De-Icing and  
Snow Melting Equipment



DESIG. 3A, 3B, 3C, 2E

### Kit Contents

Item	Qty	Description
A	4	Labels
B	1	Pipe mounting bracket
C	1	Lock nut
D	1	Blue grommet
E	1	Sealing fitting with black grommet
F	3	Wire nuts
G	1	Black heat-shrinkable tube (1/2" x 1")
H	1	Green/yellow heat-shrinkable tube (1/4" x 6")
I	2	Black heat-shrinkable tubes (1/8" x 5 1/2")
J	1	Green grounding screw and kep nut
K	1	Gel-filled end seal
L	1	Ring terminal
M	1	Black cloth tape (6" long)
N	1	Sealing gasket

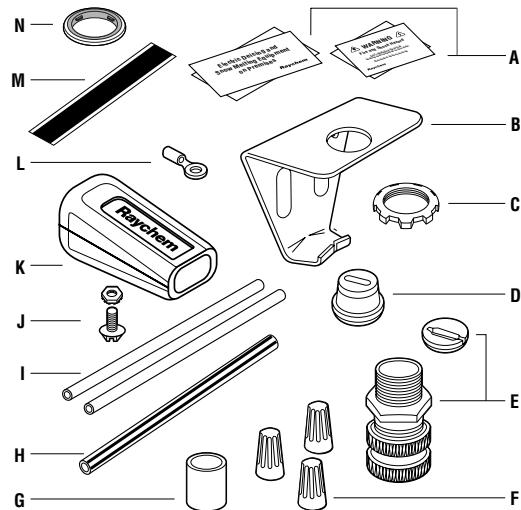

### ⚠ WARNING:

These components are electrical devices. They must be installed correctly to ensure proper operation and to prevent shock or fire. Carefully follow all of the installation instructions and read these important warnings.

- To minimize the danger of fire from sustained electrical arcing if the heating cable is damaged or improperly installed, and to comply with the requirements of Tyco Thermal Controls and national electrical codes, ground-fault equipment protection must be used on each heating cable branch circuit. Arcing may not be stopped by conventional circuit protection.
- Component approvals and performance are based on the use of specified parts only. Do not substitute parts or use vinyl electrical tape.
- The black heating-cable core is conductive and can short. It must be properly insulated and kept dry.

- Keep components and heating cable ends dry before and during installation.
- Damaged bus wires can overheat or short. Do not break braid or bus wire strands when scoring the jacket or core.
- Bus wires will short if they contact each other. Keep bus wires separated.
- Heat-damaged components can short. Use a heat gun or a torch with a soft, yellow, low-heat flame, not a blue focused flame. Keep the flame moving to avoid overheating, blistering, or charring the heat-shrinkable tubes. Avoid heating other components. Replace any damaged parts.
- Use only fire-resistant insulation materials such as fiberglass wrap.
- Leave these installation instructions with the user for future reference.

### ⚠ CAUTION:

Charring or burning the heat-shrinkable tubes in this kit will produce fumes that may cause eye, skin, nose, and throat irritation. Consult Material Safety Data Sheet RAY/3122.

24-hour emergency telephone:  
CHEMTREC (800) 424-9300.

Non-emergency health and safety information:  
(800) 545-6258.

**H900 Design and Installation Information for Heating Cable on Pipes Only**  
(WinterGard H311, H611, H621, H612, and H622 Heating Cables)

**Electrical codes**

Articles 422 and 427 of the National Electrical Code govern the installation of WinterGard heating cable for pipe freeze protection.

**Important:** For the Tyco Thermal Controls warranty to be valid, you must comply with all the requirements outlined in these guidelines.

All thermal and design information provided here is based upon a "standard" installation with heating cable fastened to an insulated pipe. For any other application or method of installation, consult Tyco Thermal Controls at (800) 545-6258.

**Heating cable selection and design**

Make sure that the heating cable being used is suitable for your application. Refer to the Heat Systems Application and Design Guide (H53585) for heating cable application information.

**1. Determine the heating cable type.**



Use Table 1 to select heating cables for insulated *metal* pipes. Use Table 2 to select heating cables for insulated *plastic* pipes. Read across the table to find your pipe size, then drop down to the line corresponding to the lowest air temperature for that application and the correct insulation thickness. The cell at that intersection has a particular shading and may have a number. The shading indicates which heating cable to use (key to the shading appears above the table headings). A number represents the spiraling ratio (feet of heating cable per foot of pipe).

If no number appears in the cell, straight trace the pipe. If a number does appear in the cell, spiral trace the pipe.



If your spiraling ratio is 2.0, multiple trace the pipe using two straight traces at the 4 o'clock and 8 o'clock positions.

If your spiraling ratio is 3.0, multiple trace the pipe using three straight traces at the 11 o'clock or 1 o'clock position, **and** at the 4 o'clock and 8 o'clock positions.



**Example 1:**



Pipe size: 1"  
 Lowest air temp.: 0°F  
 Insulation thickness: 1/2"  
 Metal pipe:  WinterGard H311  
 Plastic pipe:  WinterGard Plus H611, H621  
 WinterGard Wet H612, H622

**Example 2:**



Pipe size: 2 1/2"  
 Lowest air temp.: -20°F  
 Insulation thickness: 1/2"  
 Metal pipe:  **1.3** WinterGard Plus H611, H621  
 WinterGard Wet H612, H622  
*(Use 1.3 feet of heating cable per foot of pipe.)*  
 Plastic pipe:  **2.0** WinterGard Plus H611, H621  
 WinterGard Wet H612, H622  
*(Use two straight traces at the 4 o'clock and 8 o'clock positions.)*











**Table 1. For METAL pipes with fiberglass insulation or equivalent (based on 40°F maintain temperature, 10% safety factor)**

**Key to Table 1:**  = H311     = H611, H612, H621, H622     = Use a thicker insulation

Lowest air temp. (°F)	Insulation thickness	Nominal pipe size										
		1/2"	3/4"	1"	1 1/4"	1 1/2"	2"	2 1/2"	3"	4"	6"	8"
0	1/2"									1.3	1.8	3.0
	1"											1.3
	1 1/2"											
-20	1/2"						1.1	1.3	1.5	1.8	3.0	
	1"									1.1	1.5	1.9
	1 1/2"										1.1	1.3
	2"											
-40	1/2"				1.1	1.2	1.4	1.7	2.0	3.0		
	1"								1.1	1.4	1.9	3.0
	1 1/2"										1.4	1.7
	2"										1.1	1.4

**Table 2. For PLASTIC pipes with fiberglass insulation or equivalent (based on 40°F maintain temperature, 10% safety factor)**

**Key to Table 2:**  = H311     = H611, H612, H621, H622     = Use a thicker insulation

Lowest air temp. (°F)	Insulation thickness	Nominal pipe size										
		1/2"	3/4"	1"	1 1/4"	1 1/2"	2"	2 1/2"	3"	4"	6"	8"
0	1/2"						1.2	1.4	1.7	2.0	3.0	
	1"									1.2	1.6	2.0
	1 1/2"										1.2	1.5
-20	1/2"			1.1	1.3	1.5	1.8	2.0	3.0			
	1"						1.1	1.2	1.4	1.8	3.0	
	1 1/2"								1.1	1.3	1.7	3.0
	2"										1.4	1.7
-40	1/2"	1.1	1.1	1.5	1.8	2.0	3.0	3.0				
	1"				1.1	1.2	1.4	1.6	1.9	3.0		
	1 1/2"						1.1	1.2	1.4	1.7	3.0	3.0
	2"								1.1	1.3	1.8	3.0

## 2. Calculate the total heating cable length.

Pipe length  $\times$  spiraling ratio  
 + 4 ft  $\times$  # gate/globe valves  $\times$  valve length (ft)  $\times$  spiraling ratio  
 + 2 ft  $\times$  # ball/butterfly valves  $\times$  valve length (ft)  $\times$  spiraling ratio  
 + 2 ft  $\times$  # flanges  $\times$  pipe diameter (ft)  $\times$  spiraling ratio  
 + 2 ft  $\times$  # pipe supports  $\times$  pipe diameter (ft)  $\times$  spiraling ratio  
 + 1 ft for each power connection  
 + 2 ft for each splice connection  
 + 3 ft for each tee connection  

---

 = Total heating cable length (ft)

## 3. Determine the maximum heating cable circuit length allowed.

See Table 3 on the next page. Ensure that your circuits do not exceed the maximum circuit length listed in Table 3. If necessary, use additional shorter circuits.

**Example** (taken from Example 2 [on metal pipe], pg. 2):

Pipe length:	50 ft
Spiral ratio:	1.3 (from Table 1, pg. 2)
Globe valves:	3 (each 0.5 ft long)
Pipe supports:	10 supports for 1" pipe
Power connections:	1
Splice connections:	1
End Seals:	1

### WinterGard heating cable required:

Pipe length $\times$ spiral ratio	= 50 ft $\times$ 1.3	= 65.0 ft
3 globe valves (.5 ft each)	= 4 ft $\times$ 3 $\times$ .5 $\times$ 1.3	= 7.8 ft
10 pipe supports	= 2 ft $\times$ 10 $\times$ .085* $\times$ 1.3	= 2.2 ft
1 power connection	= 1 ft $\times$ 1	= 1.0 ft
1 splice connection	= 2 ft $\times$ 1	= 2.0 ft
1 end seal	= 0.5 ft $\times$ 1	= 0.5 ft

Total heating cable length required = 78.5 ft

\*1" pipe diameter  $\div$  12" per foot = .085 foot

## Heating cable installation

### 1. Prepare for installation.

- Store the heating cable in a clean, dry place.
- Complete piping pressure test.
- Review the WinterGard heating cable design and compare to materials received to verify that the proper WinterGard heating cable and accessories are available. The WinterGard heating cable will have the heating cable type printed on the outer jacket.
- Walk the system and plan the routing of the WinterGard heating cable on the pipe.

### 2. Cut the heating cable to length.

- Cut the heating cable to the length required. This can be done before or after the cable is attached to the pipe. Leave a minimum of 1 foot extra heating cable for connection to power. For splice and tee connections, leave a minimum of 1 foot for each section of heating cable. WinterGard heating cable can be cut to length without affecting its heat output per foot.
- Protect the heating cable ends from moisture or mechanical damage if they will be left exposed before connection.

### 3. Position and attach heating cable to pipe.

- Be sure all piping to be traced is dry.
- Install heating cable, using straight tracing, spiraling, or multiple tracing according to the "Heating cable selection and design" section on page 2.
- For straight tracing, install the heating cable on a lower half of the pipe; for example, in the 4 o'clock or 8 o'clock position.
- Be sure to install the additional heating cable required for valves, flanges, etc. as indicated in Step 2 of the "Heating cable selection and design" section.
- When the design calls for spiraling, begin by suspending a loop every 10 feet as shown in Figure 1. To determine the loop length, obtain the spiral factor from Table 1 or 2 and multiply by 10. For example, if a spiral factor of 1.3 is called for, leave a 13-foot loop of

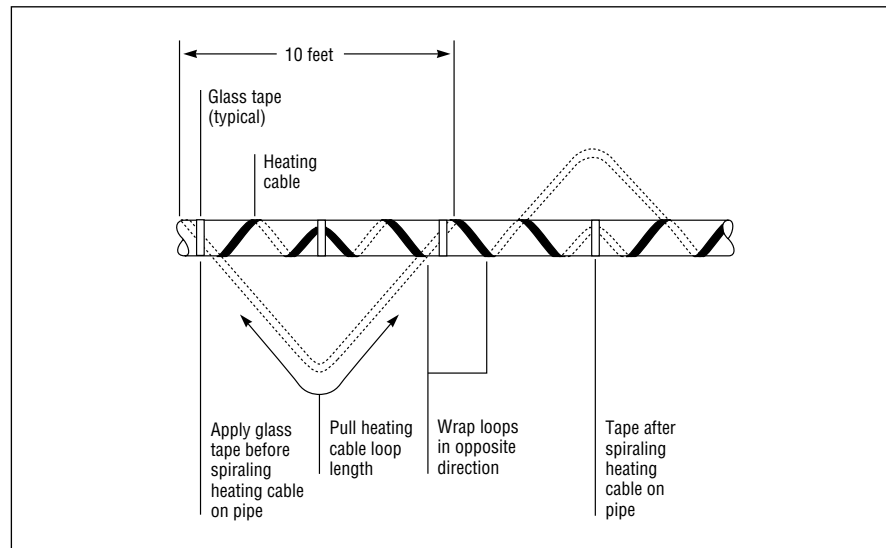

Figure 1. Spiraled heat tracing

heating cable at every 10-foot section of pipe. Grasp the loop in its center and wrap it around the pipe. Even out the distance between spirals by sliding the wraps along the pipe. Use glass tape to secure the center of the loop to the pipe. Secure the heating cable flat to the pipe to obtain good contact.

- Tape WinterGard heating cable to the pipe at 2-foot intervals using Raychem H903 fiberglass application tape or nylon cable ties. Do not use vinyl electrical tape, duct tape, metal bands, or wire.

### 4. Install heating cable end seals, splices, tees, and power connection.

- Install all end seals, splices, tees, and power connection prior to plugging in.
- If splicing or teeing, use only the H910 WinterGard Splice and Tee Kit to satisfy code and agency requirements.
- H900 kit assembly instructions begin on page 8.

### 5. Check the installation.

- Prior to installing thermal insulation, make sure the heating cable is free of mechanical damage (from cuts, clamps, etc.) and thermal damage (from solder, overheating, etc.).
- Visually check all power connections, end seals, splices, and tees.
- Using a megohmmeter, test each circuit according to the instructions in the "Heating cable testing and maintenance" section (page 4) both before and after installing the thermal insulation.

## 6. Install thermal insulation.

- A reliable WinterGard system depends on properly installed and weather-proofed thermal insulation.
- Ensure that type and thickness of the insulation are in accordance with the information in the heating cable selection tables on page 2 and that all pipe work—including valves, joints, wall penetrations, and other elements—has been fully insulated.

- Minimize the potential for mechanical damage to the heating cable after installation by installing the insulation as soon as you have checked the cable installation.

## 7. Mark the installation.

- Place “Warning” labels for pipe trace applications on the outer surface of the insulation at 10-foot intervals (on alternating sides of the pipe) to indicate the presence of WinterGard electric heating cable. Additional labels and application tape are contained in the H903 kit.

## 8. Check the installation

- Prior to powering, check to be sure the heating cable is free of mechanical damage (cuts, clamps, etc.).
- Visually check all power connections, end seals, splices, and tees for proper installation.
- Using a Megohmmeter, test each circuit according to the instructions in the “Heating cable testing and maintenance” section below.

## Electrical protection

### Voltage rating

H311, H611, and H612	110–120 Vac
H621	208–240 Vac
H622	208–277 Vac

For the maximum heating cable circuit length permitted for a given circuit breaker rating, refer to Table 3. Limit your circuit length based on your lowest anticipated start-up temperature.

### Ground fault protection:

Tyco Thermal Controls and national electrical codes require ground-fault equipment protection on each heating cable branch circuit. To reduce the risk of fire caused by damage or improper installation, circuit breakers such as Square D QO-EPD and QOB-EPD or equivalent, with a 30-mA trip level, should be used. Alternative designs providing comparable levels of ground-fault protection may also be acceptable. For technical assistance, call Tyco Thermal Controls at (800) 545-6258.

**Table 3. Maximum heating cable circuit length**

Heating cable type	Circuit breaker rating (A)	Maximum circuit length (ft) for minimum start-up temperature	
		40°F	0°F
WinterGard H311	15	250	150
	20	250	215
	30	250	250
WinterGard Plus H611	15	150	125
	20	200	160
	30	200	200
WinterGard Plus H621	15	300	225
	20	350	300
	30	350	350
WinterGard Wet H612	15	150	125
	20	200	160
	30	200	200
WinterGard Wet H622	15	320	225
	20	350	300
	30	350	350

**Note:** Circuit breaker sizing is based on Section 427-4 of the National Electrical Code. Circuit length data for H621 and H622 is correct for 208–277 volts. Maximum circuit lengths are based on start-up load. Steady-state amps per foot is dependent upon heating cable temperature.

## Heating cable testing and maintenance

Tyco Thermal Controls recommends that the insulation resistance between the bus wires and the heater grounding braid or metal pipe should be checked during installation using a 2500-Vdc megohmmeter (500 Vdc mini-mum). Minimum reading should be 20 megohms, regardless of length.

Record the original values for each circuit. Take additional readings during regularly scheduled

maintenance and compare to the original value. If the readings fall below 20 megohms, inspect cables and insulation for signs of damage.

If physical damage is found, the entire damaged section must be removed and a new section of heating cable spliced in using only approved WinterGard H910 splice kits. Do not repair the damaged heating cable section.

If physical damage cannot be found, the complete circuit should be removed and replaced with new WinterGard heating cable.

**⚠ WARNING:** Shock and Fire Hazard. Damaged heating cable or components can cause electrical shock, arcing, and fire. Do not attempt to energize damaged cable or components. Replace them immediately using a new length of heating cable and the appropriate WinterGard accessories.

**Table 4. Product data—WinterGard products on pipe only**

Heating cable type	WinterGard		WinterGard Plus		WinterGard Wet	
	H311	H611	H621	H612	H622	
Service voltage (V)	120	120	240	120	277	
Thermal output at 40°F (W/ft)	3	6	6	6	6	
Weight per 100 ft (lb)	6	6	6	9	9	
Minimum installation temp. (°F)	0	0	0	0	0	
Maximum exposure temp. (°F)	150	150	150	150	150	
Exposure to chemicals	None	None	None	None	None	
Environment	Use only in ordinary (nonhazardous) areas.		Use only in ordinary (nonhazardous) areas.		Use only in ordinary (nonhazardous) areas.	

## H900 Design and Installation Information for Roof and Gutter De-Icing Only (WinterGard Wet H612, and H622 Heating Cables)

### Electrical codes

Article 426 of the National Electrical Code governs the installation of WinterGard heating cable systems for roof and gutter de-icing.

**Important:** For the Tyco Thermal Controls warranty to be valid, you must comply with all the requirements outlined in these guidelines.

All design information provided here is based on a "standard" shake or shingle roof application. For any other application or method of installation, consult Tyco Thermal Controls at (800) 545-6258.

### Heating cable design

Only WinterGard Wet H612 120-V and H622 240-V heating cable are suitable for use with the H900 power connection kit for roof and gutter de-icing applications.

#### 1. Calculate the heating cable length required.

Total heating cable length:

- Roof edge length (ft) × feet of heating cable per foot of roof edge
- + Total gutter length (ft)
- + Total downspout length (ft)
- + 1 ft for each power connection
- + 2 ft for each splice connection
- + 3 ft for each tee connection

---

- = Total heating cable length (ft)

**Table 5. Typical spacing and layout measurements**

Roof overhang	Tracing width	Tracing height	Length of WinterGard Wet per foot of roof edge
12"	2'	18"	2'
24"	2'	30"	3'
36"	2'	42"	4'

#### Example:

Roof edge:	40 ft
Roof overhang:	1 ft
Roof gutter:	40 ft
Downspout:	15 ft
Power connection:	2 ea.
Tee connection:	1 ea.
Voltage available:	120 V

#### WinterGard Wet heating cable required:

Roof edge:	40 ft × 2 (from table above)
Roof gutter:	40 ft
Downspout:	15 ft
Power connection:	1 ft × 2 ea.
Tee connection:	3 ft × 1 ea.
<hr/>	
Total WinterGard Wet heating cable required:	140 ft*

\* This total exceeds 125-ft maximum circuit length (see page 6), therefore two separate circuits are required.

### Heating cable installation

#### 1. Prepare for installation.

- Store the heating cable in a clean, dry place.
- Use only the following Tyco Thermal Controls accessories to satisfy code and agency requirements:
  - H900 WinterGard Plug-in Power Connection Kit (with end seal)
  - H910 WinterGard Splice and Tee Kit (if splicing or teeing)
  - H915 Downspout Hangers
  - H913/H914 Roof Clips
- Carefully plan the routing of the heating cable for roof and gutter de-icing.
- Make certain gutters and downspouts are free of leaves and other debris.

#### 2. Cut the heating cable to length.

- Cut the heating cable to the length required. This can be done before or after it is installed. Leave a minimum of 1 foot extra heating cable for connection to power. For splice and tee connections leave a minimum of 1 foot for each section of heating cable. WinterGard heating cable can be cut to length without affecting its heat output per foot.
- Protect the heating cable ends from moisture and mechanical damage if they will be left exposed before connection.

#### 3. Position and attach the heating cable.

##### On roofs

- Loop the heating cable on the overhang area of the roof. This is the part that extends past the building wall. Extend the bottom of each heating cable loop over the roof edge and, using a UV-resistant cable tie, connect the bottom of each loop to the cable running in the gutter to ensure a drainage channel off the roof and into the gutter and downspout. The cable running in the gutter should remain against the bottom of the gutter. Extend the top of each heating cable loop beyond where the wall joins the roof. Tyco Thermal Controls recommends 2-foot clip-spacing along the roof edge. See the "Heating cable design" section (Table 5) for spacing and layout information.
- Use WinterGard H913/H914 roof clips to attach heating cable to the roof surface. One kit contains ten double roof clips for approximately 7 linear feet of roof edge. One H914 kit contains 50 roof clips for approximately 35 linear feet of roof edge. For flat roofs, the heating cable can be spaced as needed to create runoff paths for melting ice and snow. Use single-ended clips located at 3-foot intervals to secure the cable to the roof.

Roof clips may be attached to a shake or shingle roof with nails or screws. Reseal the nail or screw holes if necessary before installing heating cable in the clips. Roof clips may be attached to a metal roof using screw, nail or adhesive. (See H56723 installation instruction for more details.)

- A barrier (snow fence) can be placed on the roof above the heating cable. This prevents damage to the cable and keeps the installation from coming loose due to ice slides. If desired, the heating cable can be attached to the barrier with UV-resistant cable ties, instead of using roof clips. Do not use wire or other materials because they may damage the heating cable.

##### In gutters and downspouts

- Run heating cable along gutters and into downspouts, ending below the freezing level. Permanent attachment of the cable to the gutter bottom is not necessary. Loop the heating cable in downspouts if convenient, such as when the downspout is not at the end of the run, or use the H910 splice and tee kit to tee down the downspout.
- Use WinterGard H915 downspout hangers to protect the heating cable from fraying and from damage from sharp edges and to provide strain relief. Refer to the H915 kit instructions for installation details.
- Use WinterGard H913/H914 roof clips to route heating cable into and out of the gutter in such a way as to prevent abrasion to the cable. Protect all cable that protrudes past the lower opening of the downspout.

#### 4. Install heating cable end seals, splices, tees, and power connection.

- Install all end seals, splices, tees, and power connection prior to plugging in.
- Follow the H900 kit installation instructions beginning on page 8.
- Use only weatherproof junction boxes approved for wet locations when installing WinterGard H612 and H622 heating cable with the H900 Power Connection Kit for roof and gutter applications.

#### 5. Mark the installation.

A label indicating the presence of electric de-icing and snow-melting equipment on the premises is included with this unit. The label must be posted at the electrical outlet cover. The label must be clearly visible.

#### 6. Check the installation.

- Prior to powering, check to be sure the heating cable is free of mechanical damage (cuts, clamps, etc.).
- Visually check all power connections, end seals, splices, and tees for proper installation.
- Using a megohmmeter, test each circuit according to the instructions in the "Heating cable testing and maintenance" section below.

### Electrical protection

#### Voltage rating

H612	110–120 Vac
H622	208–277 Vac

#### Ground Fault Protection:

Tyco Thermal Controls and national electrical codes require ground-fault equipment protection on each heating cable branch circuit. To reduce the risk of fire caused by damage or improper installation, circuit breakers such as Square D QO-EPD and QOB-EDPD or equivalent, with a 30-mA trip level, should be used. Alternative designs providing comparable levels of ground-fault protection may also be acceptable. For technical assistance, call Tyco Thermal Controls at (800) 545-6258.

**Table 6. Maximum heating cable circuit length**

Heating cable type	Circuit breaker rating (A)	Max. heating cable circuit length (ft) for minimum start-up temperature of 0°F
WinterGard Wet H612	15	100
	20	125
	30	150
WinterGard Wet H622	15	200
	20	250

### Heating cable testing and maintenance

Make sure that gutter and downspouts are free of leaves and other debris prior to the winter season.

Tyco Thermal Controls recommends that the insulation resistance between the bus wires and the heating cable grounding braid or metal pipe should be checked during installation using a 2500-Vdc megohmmeter (500 Vdc mini-mum). Minimum reading should be 20 megohms, regardless of circuit length.

Record the original values for each circuit. Take additional readings during regularly scheduled maintenance and compare to the original value. If the readings fall below 20 megohms, inspect heating cables and insulation for signs of damage.

If physical damage is found, the entire damaged section must be removed and a new section of heating cable spliced in using only approved WinterGard H910 splice kits. Do not repair the damaged heating cable section.

If physical damage cannot be found, the complete circuit should be removed and replaced with new WinterGard heating cable.

**⚠ WARNING: Shock and Fire Hazard.** Damaged heating cable or components can cause electrical shock, arcing, and fire. Do not attempt to energize damaged cable or components. Replace them immediately using a new length of heating cable and the appropriate WinterGard accessories.

**Table 7. Product data—WinterGard Wet H612 and H622 for roof and gutter de-icing only**

	H612	H622
Service voltage (V)	120	208–277
Thermal output at 32°F (W/ft) (in ice and snow)	8	8
Weight per 100 ft (lb)	9	9
Minimum installation temp. (°F)	0	0
Maximum exposure temp. (°F)	150	150
Exposure to chemicals	None	None
Environment	Use only in ordinary (nonhazardous) areas.	Use only in ordinary (nonhazardous) areas.

**Note:**

- In all locations, route and secure cable to avoid possible mechanical damage, such as from ladders, etc.

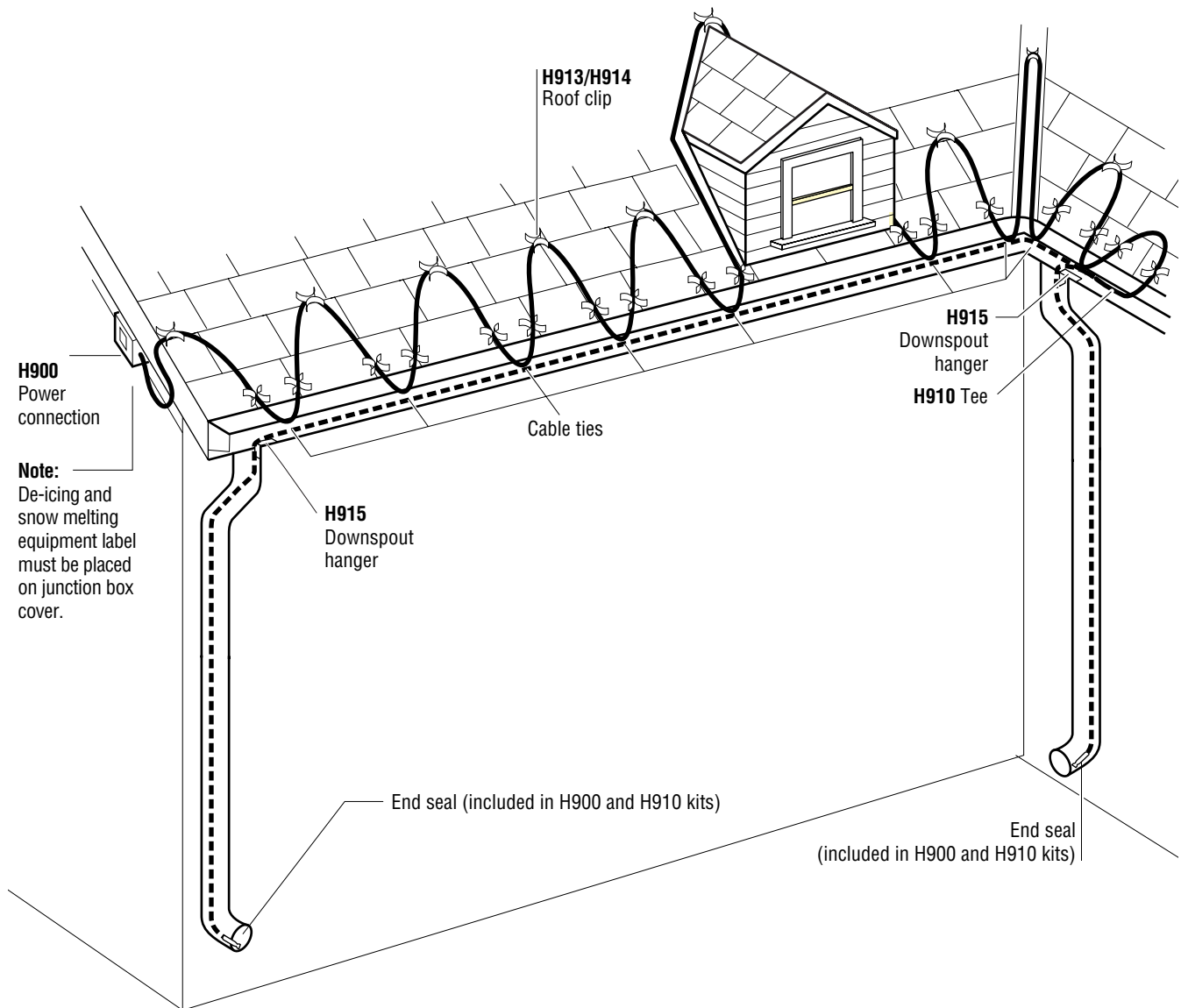

## H900 Power Connection Kit Installation Instructions

### Identify heating cable

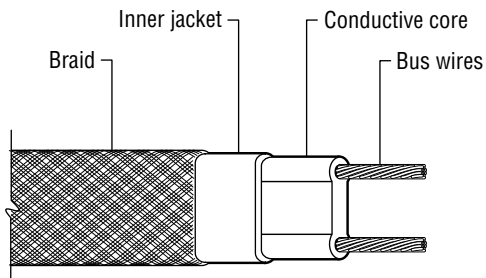

#### WinterGard H311, H611, H621

Heating cables with braid  
and no outer jacket

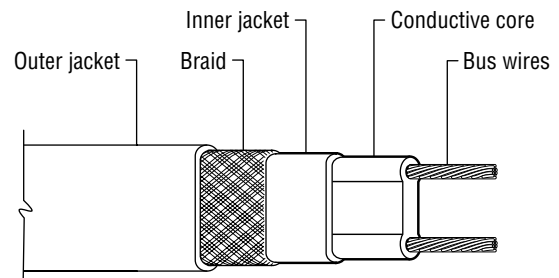

#### WinterGard H612, H622

Heating cables with braid  
and outer jacket

**Note:** Instructions generally show heating cable with braid and outer jacket. Cables with no outer jacket look slightly different from those illustrated.

### 1 For H612 and H622 heating cables only

- Open sealing fitting and discard black grommet.
- Slide parts onto cable as shown.

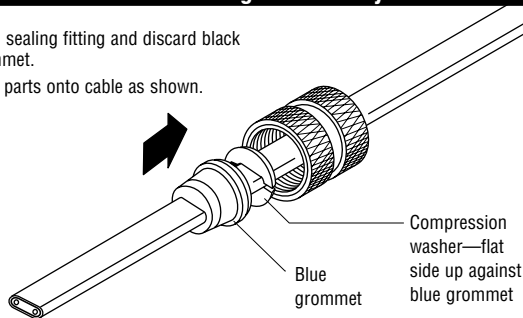

### 2 For H612 and H622 heating cables only

- Lightly score completely around and then down outer jacket.
- Bend heating cable to break jacket at score; peel off outer jacket.

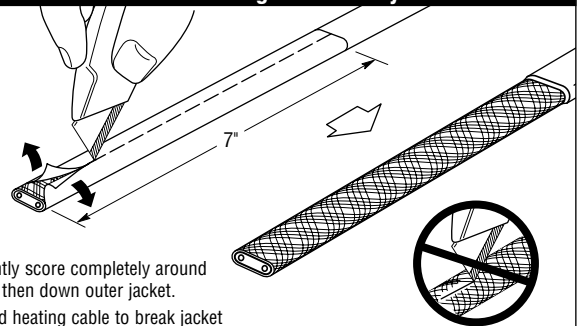

### 3

- Push braid back to loosen slightly.

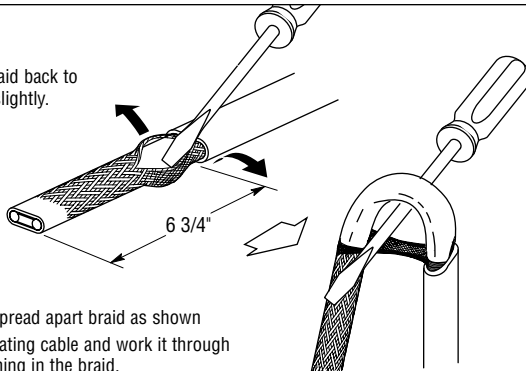

- Gently spread apart braid as shown
- Bend heating cable and work it through the opening in the braid.

### 4

- Position braid on one side of heating cable.
- Straighten the braid and twist into a "pigtail."
- Lightly score completely down and around the inner jacket.
- Bend heating cable to break jacket at score; peel off inner jacket.

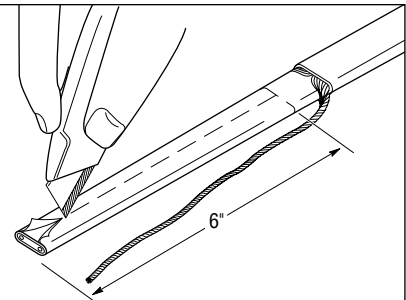



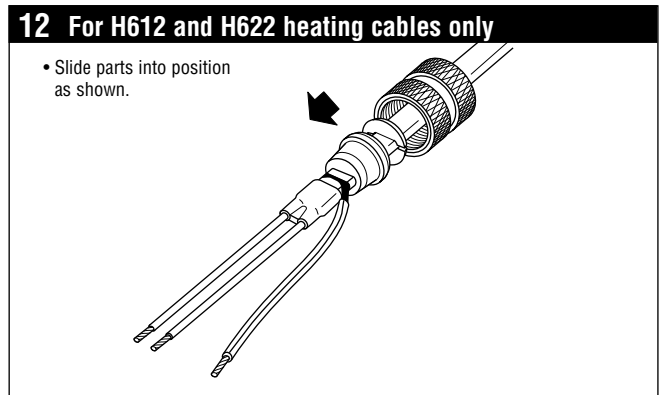
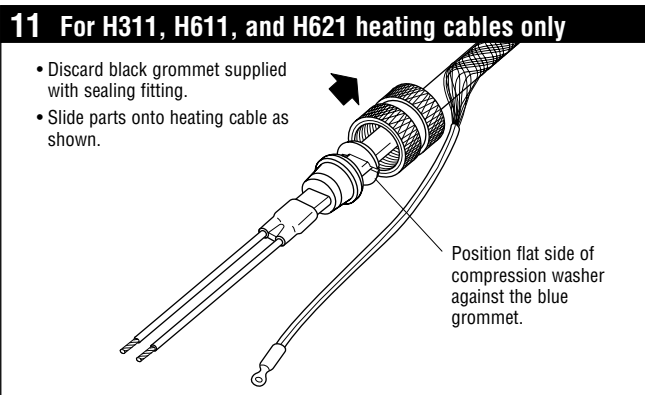
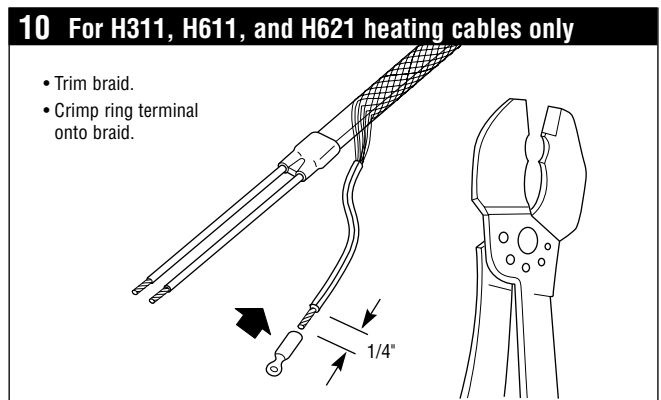
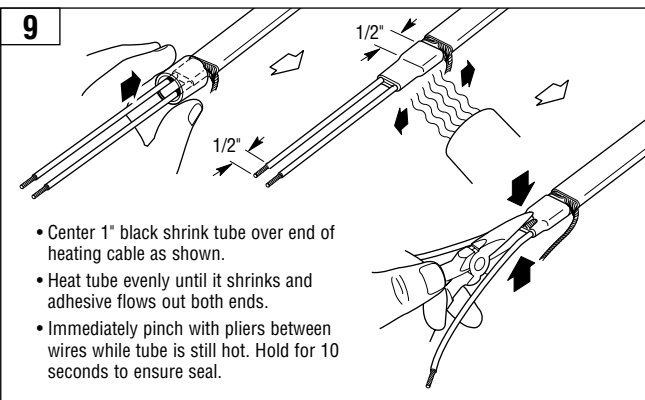
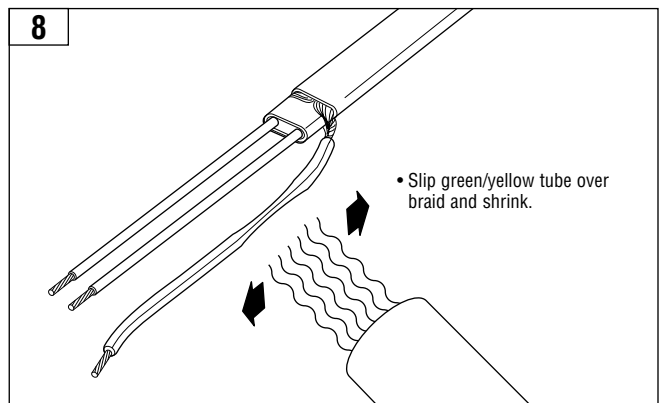
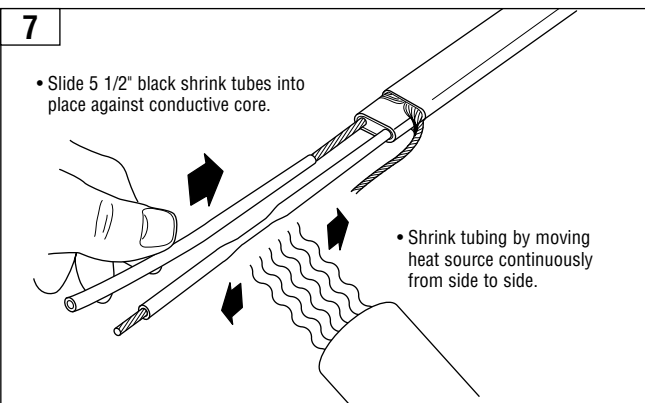
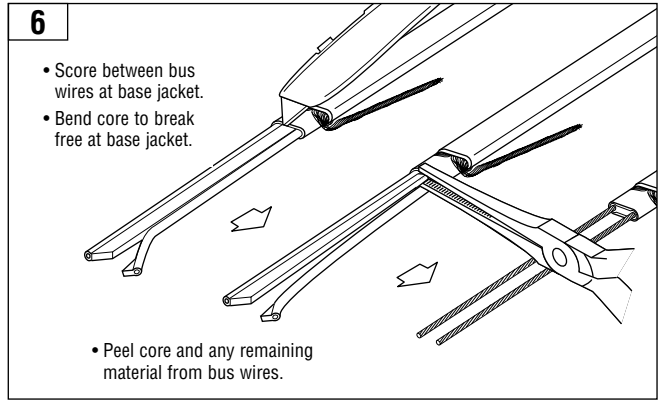
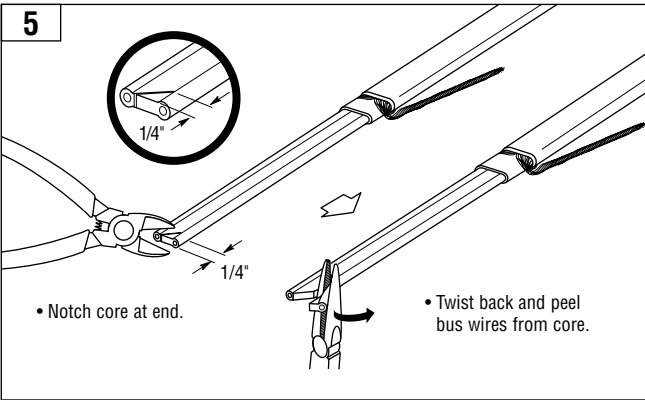

1  
2  
3  
4  
5  
6  
7  
8  
9

**H900 Power Connection Kit  
Installation Instructions**

**13 For pipe applications**

**Note:**  
For junction box with clearance hole, use lock nut.  
• Insert sealing fitting.

**14a For H311, H611, H621 heating cables only**

- Metallic junction box must be used to ensure proper ground.
- Attach ring terminal to mounting bracket as shown.
- Insert heating cable and tighten fitting.

**14b For H612, H622 heating cables only**

**Note:**  
For WinterGard Wet cables, follow instructions provided with junction box to seal against water if used in wet locations.

- Insert heating cable and tighten fitting as shown.

**15a For H311, H611, H621 heating cables only**

- Make connections shown.
- The wire nuts included are not intended for use with aluminum feed wires.

**15b For H612, H622 heating cables only**

- Make connections as shown.
- The wire nuts included are not intended for use with aluminum feed wires.

**16 For roof and gutter applications only**

- Apply "Electric De-icing" label to junction box cover.

## H900 End Seal Installation Instructions

**Note:** The end seal is designed to be installed only once; it cannot be removed from the heating cable once installed. Do not use until ready for final installation.

### 1 End Seal for H612, H622

- Cleanly cut off the end of the cable.
- Score down and around outer jacket 1 inch from the end.

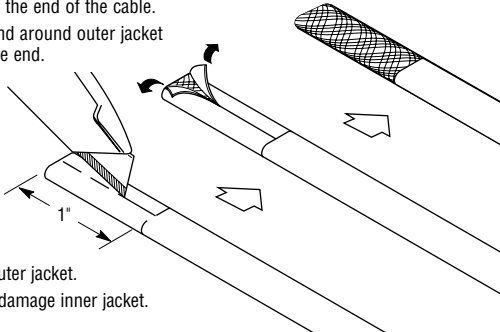

- Remove the outer jacket.
- Do not cut or damage inner jacket.

### 1 End Seal for H311, H611, H621

- Cleanly cut off the end of the cable.

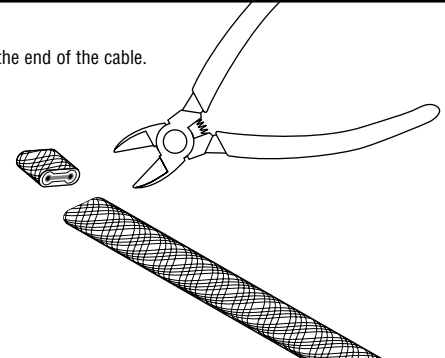

### 2

- Unravel and remove exposed braid.

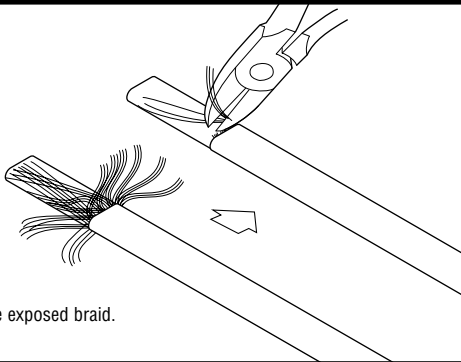

### 2

- Push the braid back 2 inches from the cable end.

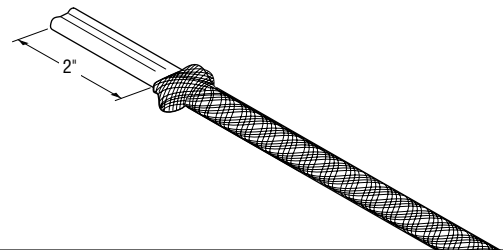

### 3

- Firmly push end seal onto the cable (at least 1 1/2 inches). Some gel may ooze out.
- Do not twist or try to remove the end seal during or after insertion. Do not reuse an end seal.

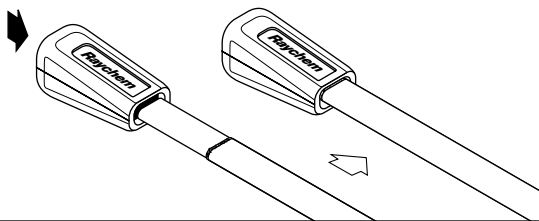

### 3

- Firmly push end seal onto the cable (at least 1 1/2 inches). Some gel may ooze out.
- Do not twist or try to remove the end seal during or after insertion. Do not reuse an end seal.

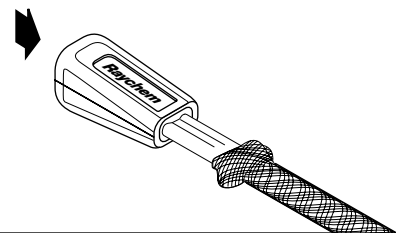

### 4

- Slide the braid up against the end seal and secure with the 6-inch length of tape provided.

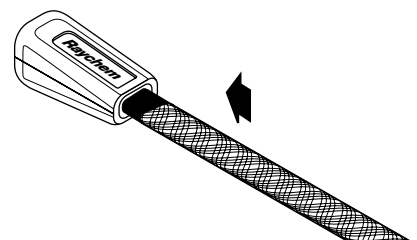

### Limited Warranty

Tyco Thermal Controls warrants all Raychem wholesale distribution self-regulating heating cables and components against faulty workmanship and use of defective materials for two (2) years from the date of purchase. This warranty can be amended only by a written instrument signed by a duly authorized officer of Tyco Thermal Controls. Buyer's exclusive remedy under this warranty shall be to have Tyco Thermal Controls, within a reasonable time, repair such goods or supply replacement goods or credit Buyer's account for such goods and accept their return whichever Tyco Thermal Controls may elect at its sole discretion. Tyco Thermal Controls shall in no event be liable for the cost of removal or installation, for loss or damage to or loss of use of facilities or other property, loss of revenue, loss of use of revenue, loss of anticipated profits, or other damages or costs of any kind whatsoever, whether direct, indirect, incidental, or consequential.

Notwithstanding the foregoing, Tyco Thermal Controls shall have no liability whatsoever unless: (a) Buyer promptly notifies Tyco Thermal Controls in writing after discovery of an alleged nonconformity and includes a detailed explanation of the alleged nonconformity; (b) Buyer promptly returns the goods to Tyco Thermal Controls postage prepaid, at 300 Constitution Drive, Menlo Park, California 94025-1164, USA; and (c) Tyco Thermal Controls examination of such goods establishes to Tyco Thermal Controls satisfaction that such alleged nonconformities actually exist and occurred in the cause of proper and normal use and were not caused by accident, misuse, neglect, alteration or improper installation, repair or testing or such other cause outside of the responsibility of Tyco Thermal Controls under this Limited Warranty.

THE FOREGOING WARRANTY IS IN LIEU OF ALL OTHER REPRESENTATIONS, WARRANTIES, OR CONDITIONS, EXPRESS OR IMPLIED, INCLUDING WITHOUT LIMITATION ANY IMPLIED WARRANTY OF MERCHANTABILITY, FITNESS FOR A PARTICULAR PURPOSE OR NON-INFRINGEMENT, AND OF ANY OTHER OBLIGATION OR LIABILITY ON THE PART OF TYCO THERMAL CONTROLS, WHETHER BY STATUTE, CONTRACT, STRICT LIABILITY, TORT OR OTHERWISE.

If the goods are a consumer product in buyer's jurisdiction, the above exclusion or limitation of incidental or consequential damages and the above disclaimer of implied warranties may not apply. The term of any such implied warranty is limited to the term of this two-year Limited Warranty. Some jurisdictions do not allow limitations on how long an implied warranty lasts, so the above limitation may not apply. This warranty gives consumers specific legal rights, and consumers may also have other rights, which vary by jurisdiction.

*TYCO, WinterGard, WinterGard Plus and WinterGard Wet are trademarks of Tyco Thermal Controls LLC or its affiliates.*

#### Worldwide Headquarters

**Tyco Thermal Controls**  
300 Constitution Drive  
Menlo Park, California 94025-1164  
Tel (800) 545-6258  
Fax (800) 596-5004  
info@tycothermal.com  
[www.tycothermal.com](http://www.tycothermal.com)

#### North America

**Tyco Thermal Controls**  
250 West Street  
Trenton, Ontario K8V 5S2  
Canada  
Tel (800) 545-6258  
Fax (800) 596-5004