



## NC-1 Condensate Neutralizer Technical Information

**KIT CONTENTS :**



No.	Parts Description
A	Two NC Series O-Rings for Canister
B	Two NC Series Unions
C	One NC Series Y Connector - Nylon
D	Three 3/4" NPT to 1/2" Hose Barb Fittings
E	Six Hose Clamps
F	10ft of 1/2 Vinyl Tubing
G	Two Base/Wall Mounting Clamps

**DIMENSIONS :**

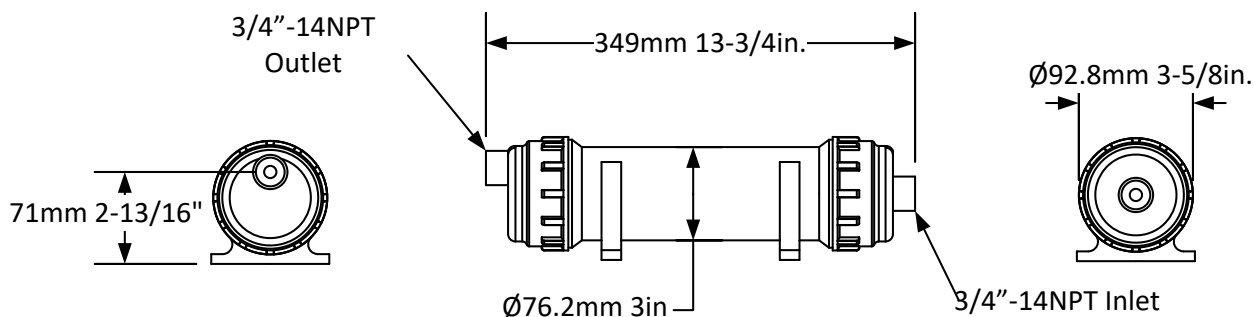

**WEIGHT :** 2 kg, 4.4 lbs. (dry weight with Media)

**SPECIFICATION :**

The condensate neutralization capsule shall be AXIOM INDUSTRIES LTD. model NC-1. System shall include 1 litre (0.26 U.S. gallon) transparent capsule made from corrosion resistant materials with two 3" fill/access openings, 3" inlet and outlet screen, 3/4"-14NPT threaded inlet, 3/4"-14NPT threaded outlet, two 3/4" MNPT x 3/4" FNPT unions, three 3/4" NPT to 1/2" hose barb fittings, 1/2" barbed Y fitting, six hose clamps, 10 ft of 1/2" ID vinyl tubing, two base/wall mounting clamps.

**OPTIONAL ACCESSORIES :**

- NM-1** -- Replacement LipHter<sup>+</sup> neutralization media (Exact Refill)
- NM-1BULK** -- Replacement LipHter<sup>+</sup> neutralization media (Up to 15 Refills)



**LIMITED WARRANTY :**

The "NC-1" is warranted against defects in materials and workmanship for one year.

Project \_\_\_\_\_  
 Consultant \_\_\_\_\_  
 Unit Tag \_\_\_\_\_

Location \_\_\_\_\_  
 Contractor \_\_\_\_\_  
 Sales Agent \_\_\_\_\_