

↗ DOMETIC

MOBILE COOLING

CFX 3



CFX3 25, CFX3 35, CFX3 45, CFX3 55, CFX3 55IM, CFX3 75DZ, CFX3 95DZ

EN **Compressor Cooler**
Short operating manual

© 2020 Dometic Group. The visual appearance of the contents of this manual is protected by copyright and design law. The underlying technical design and the products contained herein may be protected by design, patent or be patent pending. The trademarks mentioned in this manual belong to Dometic Sweden AB. All rights are reserved.

⚠ DANGER

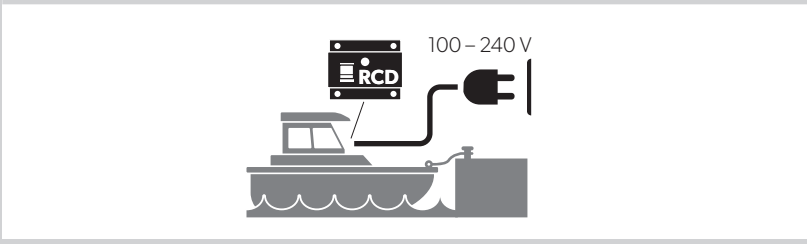
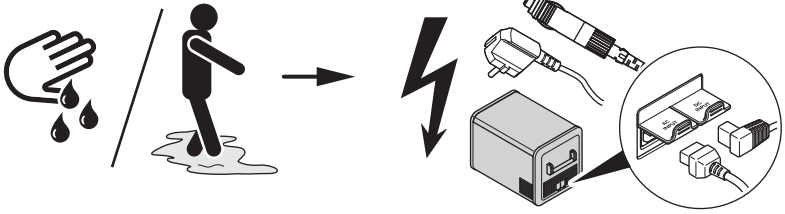

⚠ WARNING

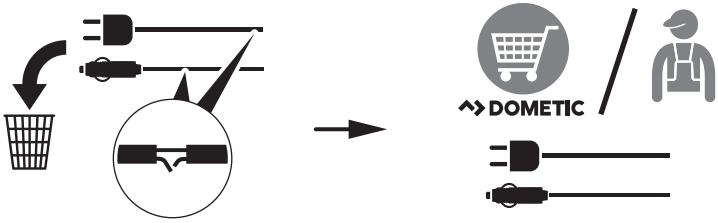

⚠ CAUTION

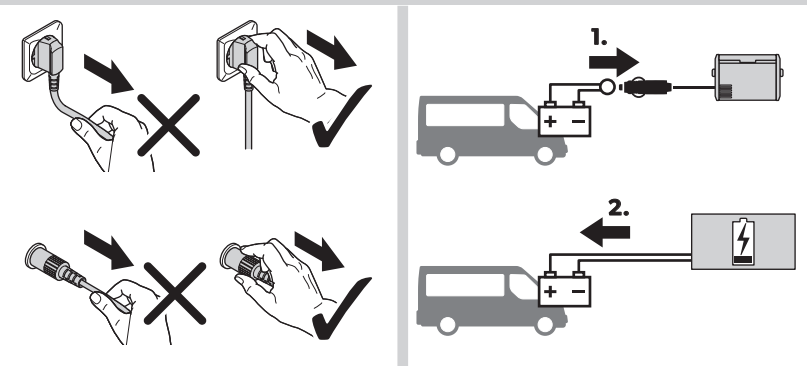

CAUTION

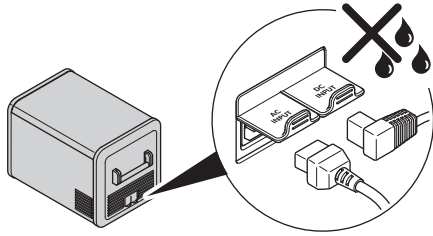

NOTICE

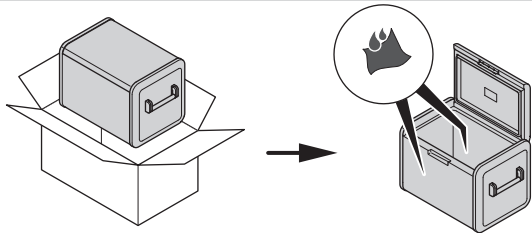
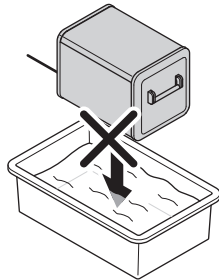
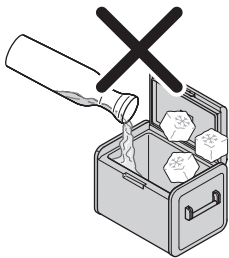
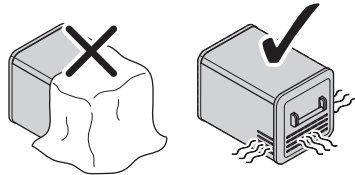
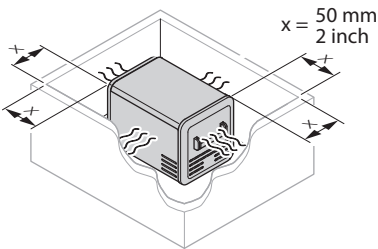
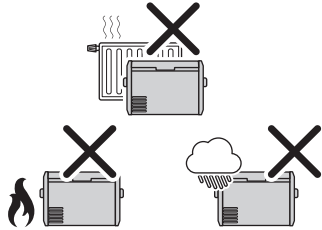
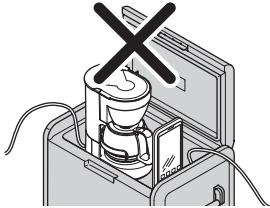

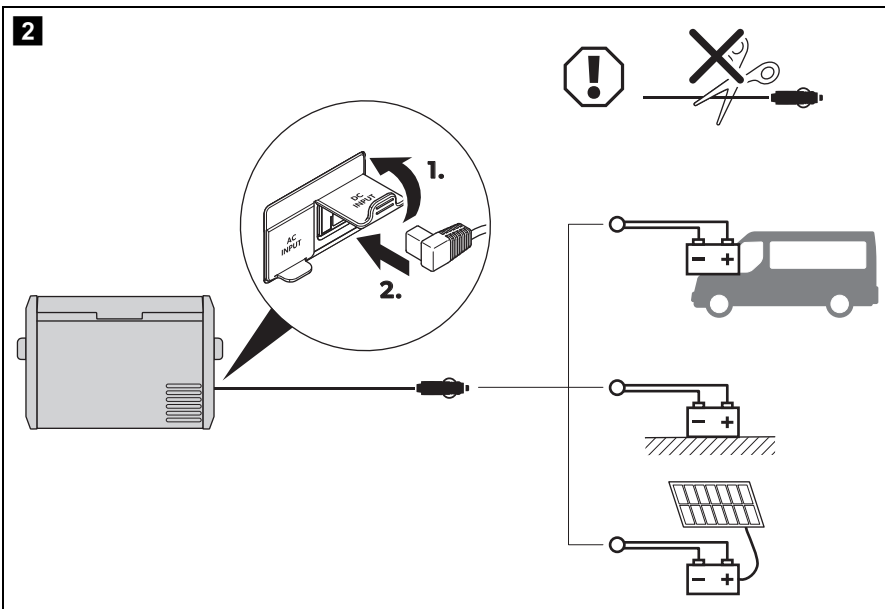
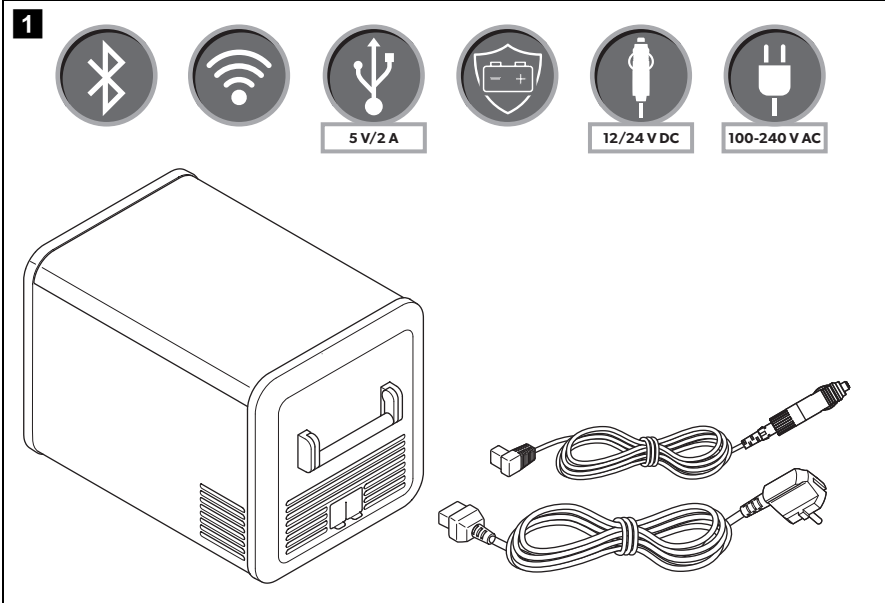

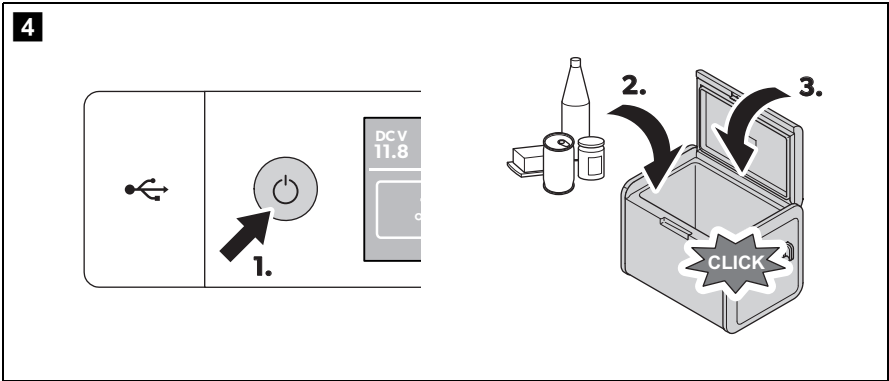
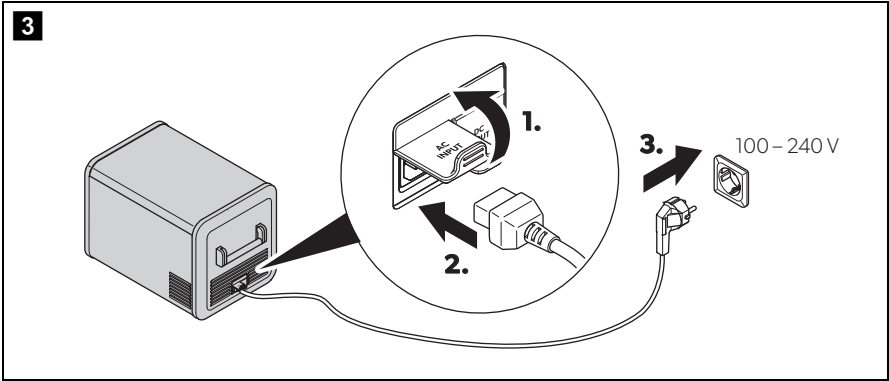

5

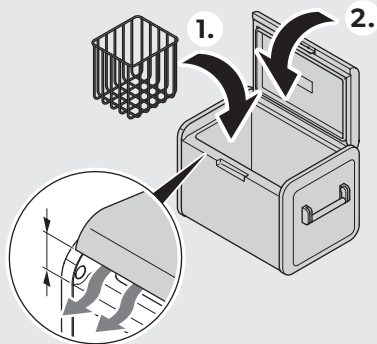
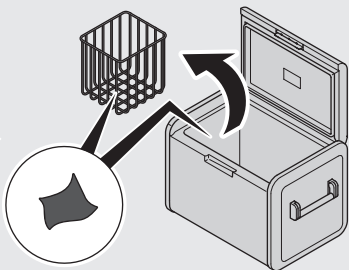
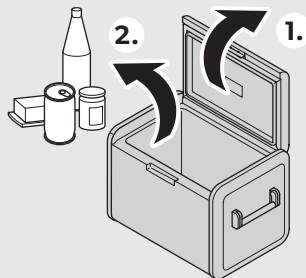
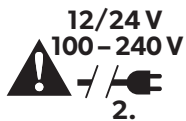
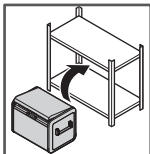

6

CFX3 25/CFX3 35/
CFX3 35/CFX3 55

CFX3 55IM

CFX3 75DZ/
CFX3 95DZ

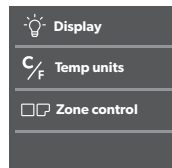
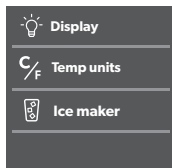
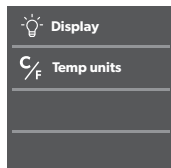
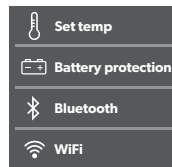
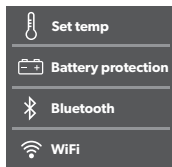
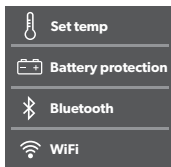
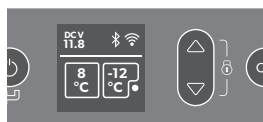
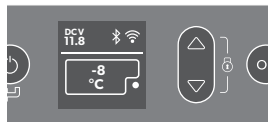

7

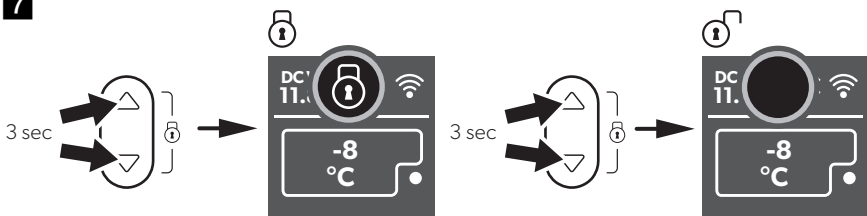

8

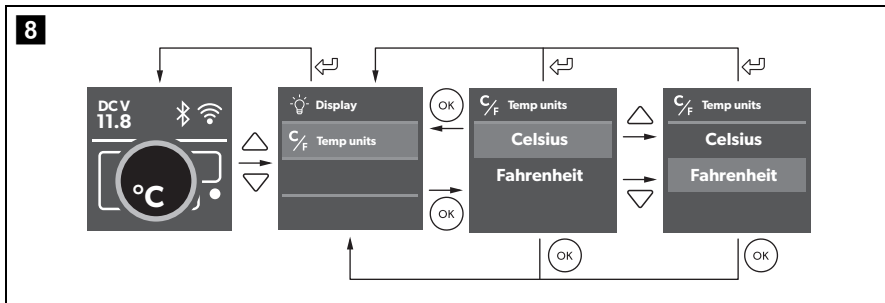

9

CFX3 25/CFX3 35/CFX3 45/CFX3 55/CFX3 55IM

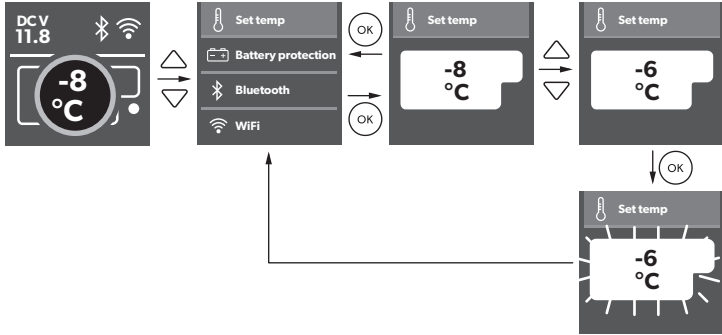

CFX3 75DZ/CFX3 95DZ

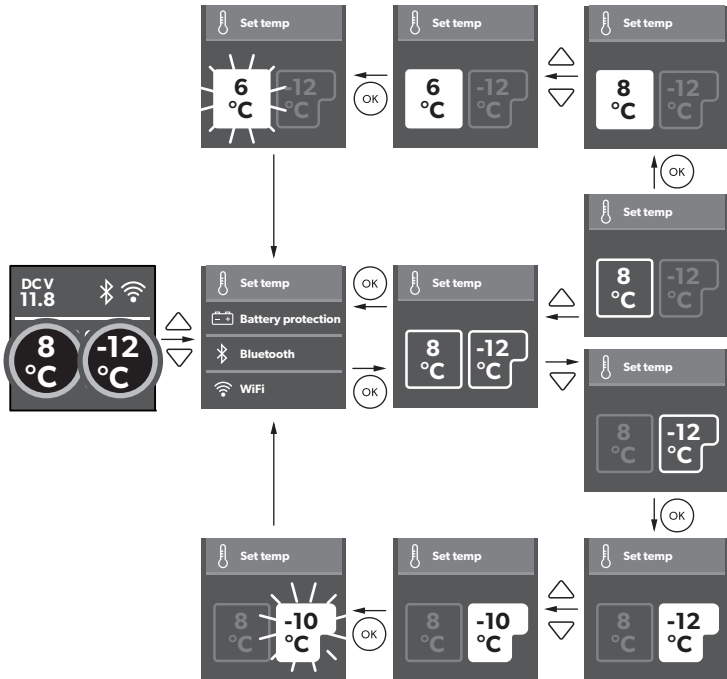

10

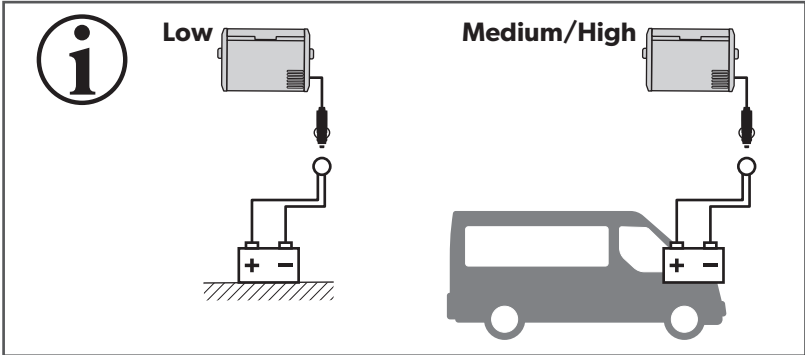
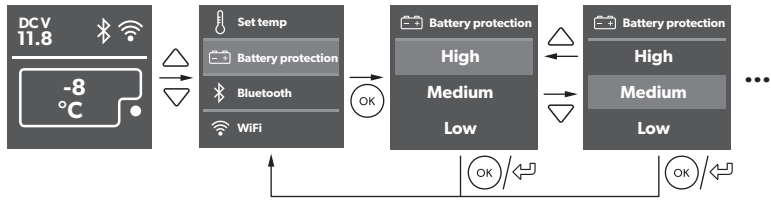

		Low	Medium	High
12V 	OFF	10.1V	11.2V	11.8V
	ON	11.4V	12.2V	12.6V
24V 	OFF	21.5V	24.1V	24.6V
	ON	23.0V	25.3V	26.2V

11

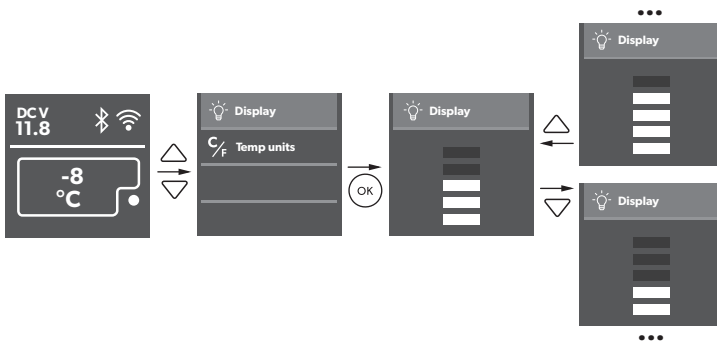

12

CFX3 75DZ/CFX3 95DZ

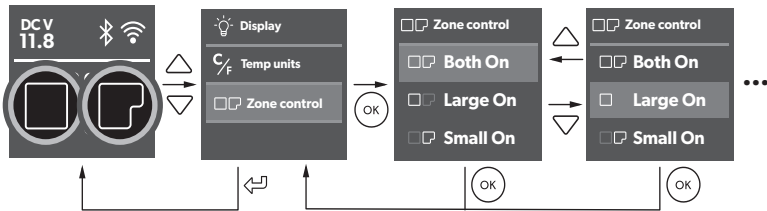

13

CFX3 55 IM

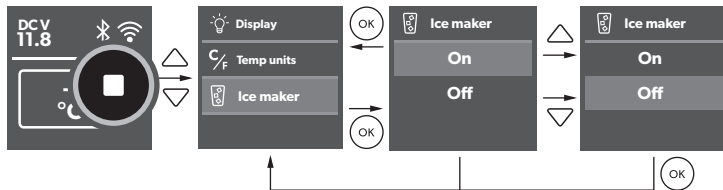

14

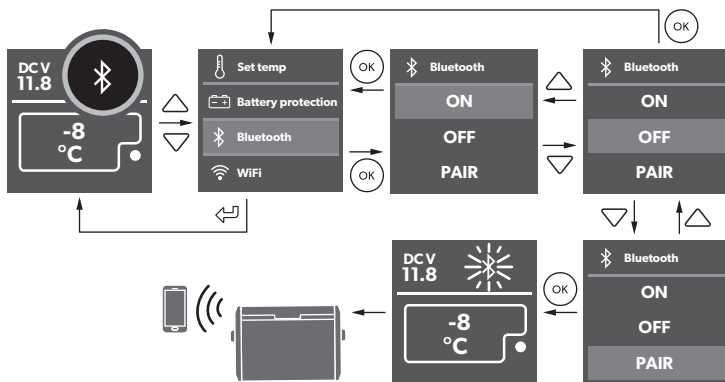

Please read this manual carefully before starting the device. Keep it in a safe place for future reference. If the device is passed on to another person, this manual must be handed over to the user along with it.

The manufacturer cannot be held liable for damage resulting from **improper usage** or **incorrect operation**.

 Find the full operating manual online either:

- In the documents section under your model at dometic.com, or;
- At dometic.com/manuals



WARNING!

Also observe the safety instructions on page 3 to page 4.

Safety instructions



WARNING! Failure to obey these warnings could result in death or serious injury.

Electrocution hazard

- Do not operate the cooling device if it is visibly damaged.

- If this cooling device's power cable is damaged, it must be replaced by the manufacturer, customer service or a similarly qualified person in order to prevent safety hazards.
- This cooling device may only be repaired by qualified personnel. Improper repairs can lead to considerable hazards.

Health hazard

- This device can be used by children aged from 8 years and above and persons with reduced physical, sensory or mental capabilities or lack of experience and knowledge if they have been given supervision or instruction concerning use of the device in a safe way and understand the hazards involved.
- Children shall not play with the device.
- Cleaning and user maintenance shall not be made by children without supervision.
- Children aged from 3 to 8 years are allowed to load and unload refrigerating devices.

Explosion hazard

- Do not store any explosive substances such as spray cans with a flammable propellant in the cooling device.

Fire hazard

- When positioning the device, ensure the supply cord is not trapped or damaged.
- Do not locate multiple portable socket-outlets or portable power supplies at the rear of the device.
- Keep the ventilation openings on the device housing or in installations free of obstructions.
- Do not use any mechanical objects or other means to speed up the defrosting process, unless they have been recommended by the manufacturer for this purpose.
- Do not damage the refrigerant circuit.



CAUTION! Failure to obey these cautions could result in minor or moderate injury.

Health hazard

- Please check if the cooling capacity of the device is suitable for storing the food or medicine you wish to cool.
- Food may only be stored in its original packaging or in suitable containers.
- Opening the lid for long periods can cause significant increase of the temperature in the compartments of the device.

- Clean regularly surfaces that can come in contact with food and accessible drainage systems.
- Store raw meat and fish in suitable containers in the device, so that it is not in contact with or can drip onto other food.
- If the device is left empty for long periods:
 - Switch off the device.
 - Defrost the device.
 - Clean and dry the device.
 - Leave the lid open to prevent mould developing within the device.



NOTICE! Damage hazard

- Only carry the cooling device upright.
- Check that the voltage specification on the type plate corresponds to that of the energy supply.
- Do not use electrical devices inside the cooling device unless they are recommended by the manufacturer for the purpose.
- **Hazard from excessively low temperature**
Ensure that only those objects are placed in the cooling device that are intended to be cooled at the selected temperature.
- The cooling device shall not be exposed to rain.

Intended use

The device is suitable for:

- Operation in vehicles
- Cooling and deep-freezing food
- Camping use

The device is **not** suitable for:

- Storage of corrosive, caustic or solvent-containing substances
- Quick-freezing of food

Operation

Scope of delivery: fig. **1**

Proceed as shown:

- Connecting to a battery: fig. **2**
- Connecting to an AC power supply: fig. **3**
- Switching on the cooler: fig. **4**
- Switching off and storing the cooler: fig. **5**
- Display overview: fig. **6**
- Locking/unlocking the display: fig. **7**
- Selecting the temperature units: fig. **8**
- Setting the temperature: fig. **9**
- Using the battery monitor: fig. **10**
- Setting the display's brightness: fig. **11**
- Switching on or off the compartments: fig. **12**
- Switching on or off the icemaker: fig. **13**
- Setting the Bluetooth signal: fig. **14**
- Setting the WiFi signal: fig. **15**
- Resetting to factory settings: fig. **16**
- Using USB port for power supply: fig. **17**

Warranty

If the product does not work as it should, please contact your retailer or the manufacturer's branch in your country (see dometic.com/dealer). The warranty applicable to your product is 3 years (full) plus additional 2 years compressor (parts only).

For repair and warranty processing, please include the following documents when you send in the device:

- A copy of the receipt with purchasing date
- A reason for the claim or description of the fault

Australia only

Our goods come with guarantees that cannot be excluded under the Australian Consumer Law. You are entitled to a replacement or refund for a major failure and for compensation for any other reasonably foreseeable loss or damage. You are also entitled to have the goods repaired or replaced if the goods fail to be of acceptable quality and the failure does not amount to a major failure.

New Zealand only

This warranty policy is subject to the conditions and guarantees which are mandatory as implied by the Consumer Guarantees Act 1993(NZ).

Disposal

- Place the packaging material in the appropriate recycling waste bins wherever possible.



If you wish to finally dispose of the product, ask your local recycling centre or specialist dealer for details about how to do this in accordance with the applicable disposal regulations.

Mobile living made easy.



dometic.com

**YOUR LOCAL
DEALER**

dometic.com/dealer

**YOUR LOCAL
SUPPORT**

dometic.com/contact

**YOUR LOCAL
SALES OFFICE**

dometic.com/sales-offices

A complete list of Dometic companies, which comprise the Dometic Group, can be found in the public filings of:
DOMETIC GROUP AB Hemvärnsgatan 15 SE-17154 Solna Sweden