



QuickFacts

NPE-2 Series Tankless Water Heaters

Navien Certification Summary Note: all NPE-2 models are field convertible from NG to LP gas

Model	Product Approvals					Efficiency Ratings*			Annual Energy Consumption* (Residential)		
	CSA	NSF (Standard 5)	Low Lead (<0.25%)	SCAQMD 1146.2 (NOx, <20ppm)	AHRI Number	Energy Star	Uniform Energy Factor (UEF)	Max GPM (L/m) (67°F Rise)	Natural Gas (Therms/Year)	Propane (Gallons/Year)	Estimated Operating Cost**
NPE-180A2-NG	Yes	Yes	Yes	Yes	206368357	Yes	0.95	4.3 (16)	179		\$195
NPE-180A2-LP	Yes	Yes	Yes	Yes	206368357	Yes	0.95	4.3 (16)		196	\$472
NPE-210A2-NG	Yes	Yes	Yes	Yes	206368358	Yes	0.95	5.1 (19)	179		\$195
NPE-210A2-LP	Yes	Yes	Yes	Yes	206368358	Yes	0.95	5.1 (19)		196	\$472
NPE-240A2-NG	Yes	Yes	Yes	Yes	206368359	Yes	0.95	5.6 (21)	179		\$195
NPE-240A2-LP	Yes	Yes	Yes	Yes	206368359	Yes	0.95	5.6 (21)		196	\$472
NPE-150S2-NG	Yes	Yes	Yes	Yes	206423843	Yes	0.93	3.4 (13)	120		\$131
NPE-150S2-LP	Yes	Yes	Yes	Yes	206423843	Yes	0.93	3.4 (13)		131	\$316
NPE-180S2-NG	Yes	Yes	Yes	Yes	206368360	Yes	0.96	4.4 (17)	177		\$193
NPE-180S2-LP	Yes	Yes	Yes	Yes	206368360	Yes	0.96	4.4 (17)		194	\$468
NPE-210S2-NG	Yes	Yes	Yes	Yes	206368361	Yes	0.96	5.3 (20)	177		\$193
NPE-210S2-LP	Yes	Yes	Yes	Yes	206368361	Yes	0.96	5.3 (20)		194	\$468
NPE-240S2-NG	Yes	Yes	Yes	Yes	206368362	Yes	0.96	5.8 (22)	177		\$193
NPE-240S2-LP	Yes	Yes	Yes	Yes	206368362	Yes	0.96	5.8 (22)		194	\$468

*Based on U.S. Department of Energy (DOE) test procedures.

**Based on a national average natural gas cost of \$1.09/therm, propane cost of \$2.41/gallon.

Temperature Rise (maximum output)

Temp Rise (°F)	150S2 GPM (L/m)	180A2/S2 GPM (L/m)	210A2/S2 GPM (L/m)	240A2/S2 GPM (L/m)
35	6.8 (26)	8.4 (32)	10.1 (38)	11.2 (42)
40	5.9 (22)	7.4 (28)	8.8 (33)	9.8 (37)
45	5.3 (20)	6.5 (25)	7.8 (30)	8.7 (33)
50	4.8 (18)	5.9 (22)	7.1 (27)	7.8 (30)
55	4.3 (16)	5.3 (20)	6.4 (24)	7.1 (27)
60	4.0 (15)	4.9 (19)	5.9 (22)	6.5 (25)
65	3.7 (14)	4.5 (17)	5.4 (20)	6.0 (23)
70	3.4 (13)	4.2 (16)	5.0 (19)	5.6 (21)
75	3.2 (12)	3.9 (15)	4.7 (18)	5.2 (20)
80	3.0 (11)	3.7 (14)	4.4 (17)	4.9 (19)
85	2.8 (11)	3.5 (13)	4.2 (16)	4.6 (17)
90	2.6 (10)	3.3 (12)	3.9 (15)	4.4 (17)
100	2.4 (9)	2.9 (11)	3.5 (13)	3.9 (15)
110	2.2 (8)	2.7 (10)	3.2 (12)	3.6 (14)
120	2.0 (8)	2.5 (9)	2.9 (11)	3.3 (12)
130	1.8 (7)	2.3 (9)	2.7 (10)	3.0 (11)
140	1.7 (6)	2.1 (8)	2.5 (9)	2.8 (11)

DHW Capacity

Models	Natural Gas (BTU/H)	Propane Gas (BTU/H)
NPE-150S2	18,000–120,000	18,000–120,000
NPE-180A2/S2	10,000–150,000	10,000–150,000
NPE-210A2/S2	12,000–180,000	12,000–180,000
NPE-240A2/S2	13,300–199,900	13,300–199,900

Operating Cost

Navien tankless	179 therms	\$195*
Other tankless	209 therms	\$228*
Standard tank	269 therms	\$293*

*Based on Energy Guide cost estimates using \$1.09 per therm of natural gas. Cost is in US dollars.

Warranty

Application		Labor	Parts	Heat Exchanger
Residential	Standard or controlled recirculation ²	1 year	5 years	15 years
	Uncontrolled recirculation ³	1 year	3 years	5 years
Commercial or Combi ¹	Standard or controlled recirculation ²	1 year	5 years	8 years
	Uncontrolled recirculation ³	1 year	3 years	3 years

¹Combi refers to a combination potable water and space heating application. Water heaters cannot be used in space heating only applications.

²Controlled-Recirculation: Recirculation through the water heater is controlled by either the water heater or an external aquastat.

³Uncontrolled-Recirculation: External pumps configured to circulate continuously through the water heater are subject to the uncontrolled recirculation warranty terms. An aquastat is the minimum pump control requirement for DHW or storage tank recirculation in order to maintain the full controlled recirculation warranty.

For complete details please refer to the full warranty at Navieninc.com.

U.S. Green Building Council LEED Points*

Water Heater	Location	Recirculation
1.5 Points	2 Points	3 Points

Lower HERS Home Index Score*

*Please consult your Energy/LEED consultant.

Product Features



Dimensions

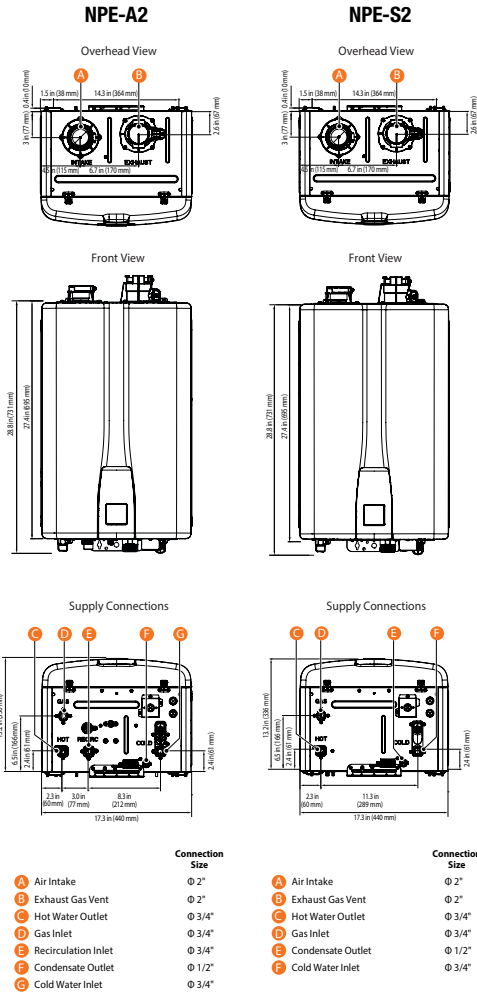

Specifications

Item	NPE-150S2	NPE-180A2	NPE-180S2	NPE-210A2	NPE-210S2	NPE-240A2	NPE-240S2
Heat capacity (input)	Natural gas 18,000–120,000 BTU/H	10,000–150,000 BTU/H		12,000–180,000 BTU/H		13,300–199,900 BTU/H	
Energy factor	UEF (for NG & LP) 0.93	0.95	0.96	0.95	0.96	0.95	0.96
Flow rate (DHW)	35°F (19°C) temp rise	6.8 GPM (26 L/m)	8.4 GPM (32 L/m)	10.1 GPM (38 L/m)		11.2 GPM (42 L/m)	
	45°F (25°C) temp rise	5.3 GPM (20 L/m)	6.5 GPM (25 L/m)	7.8 GPM (30 L/m)		8.7 GPM (33 L/m)	
	67°F (36°C) temp rise	3.4 GPM (13 L/m)	4.3 GPM (16 L/m)	4.4 GPM (17 L/m)	5.1 GPM (19 L/m)	5.3 GPM (20 L/m)	5.6 GPM (21 L/m)
Dimensions	17.3" (W) x 27.4" (H) x 13.2" (D)						
Weight	62 lbs (28 kg)	73 lbs (33 kg)	68 lbs (31 kg)	77 lbs (35 kg)	73 lbs (33 kg)	77 lbs (35 kg)	73 lbs (33 kg)
Installation type	Indoor or outdoor wall-hung						
Venting type	Forced draft direct-vent						
Ignition	Electronic ignition						
Water pressure	15–150 PSI						
Natural gas supply pressure (from source)	3.5" WC–10.5" WC						
Propane gas supply pressure (from source)	8" WC–13" WC						
Natural gas manifold pressure (min-max)	-0.04" WC– -0.40" WC	-0.03" WC– -0.55" WC		-0.03" WC– -0.76" WC		-0.03" WC– -0.96" WC	
Propane gas manifold pressure (min-max)	-0.03" WC– -0.40" WC	-0.02" WC– -0.55" WC		-0.02" WC– -0.76" WC		-0.02" WC– -0.96" WC	
Minimum flow rate	0.5 GPM (1.9 L/m), < 0.01 GPM (0.04 L/m) option for "A2" models*						
Connection sizes	Cold water inlet	3/4" NPT					
	Hot water outlet	3/4" NPT					
	Gas inlet	3/4" NPT					
Power supply	Main supply	120V AC, 60 Hz					
	Maximum power consumption	200 W (max 2 A), 350 W (max 4 A) with external pump connected					
Materials	Casing	Cold rolled carbon steel					
	Heat exchangers	Primary heat exchanger: stainless steel Secondary heat exchanger: stainless steel					
Venting	Exhaust	2" or 3" PVC, CPVC, approved polypropylene and stainless steel 2" or 3" special gas vent type BH (Class II, A/B/C)					
	Intake	2" or 3" PVC, CPVC, approved polypropylene and stainless steel 2" or 3" special gas vent type BH (Class II, A/B/C)					
	Vent clearances	0" to combustibles					
High elevations	10,100 feet for both NG or LP gas. Please refer to Installation Manual for additional details and instructions.						
Safety devices	Flame rod, APS, ignition operation detector, water temperature high limit switch, exhaust temperature high limit sensor, power surge fuse, burner high limit fuse, vent installation detector (VID)						

*Available for NPE-A2 models configured in an optional ComfortFlow® recirculation mode. Energy consumption will increase when the system is configured for recirculation.

Navien reserves the right to change specifications at any time without prior notice. Please refer to www.Navieninc.com to verify you have the most current information.

Accessories



Navien Inc., 20 Goodyear, Irvine, CA 92618 800-519-8794 Navieninc.com



THE LEADER IN CONDENSING TECHNOLOGY