

RPL45 US + SS20

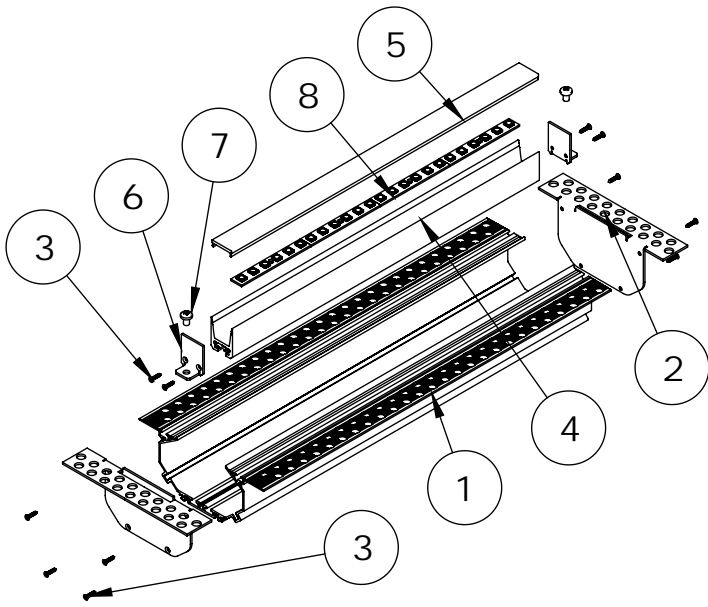

List of luminaire components

Item	Code	Comments	llo	Quantity
1	AL-RPL45 US	2,3 or 6.1[m]	1	1
2	EC-RPL45 US	end cap	2	2 per luminaire
3	DIN 7982 ST2.2x9.5	in set	12	2 per end cap
4	AL-INS-SS20B	2, 3 or 6.1 [m]	1	1
5	AB-SS20B	2, 3 or 6.1 [m]	1	1
6	EC-INS-SS20B	end cap	2	2 per luminaire
7	DIN 7985 M4 x 6	in set	2	2 per luminaire
8	10-5060	PCB 24V DC LED 5060	4	5 per 1 [m]

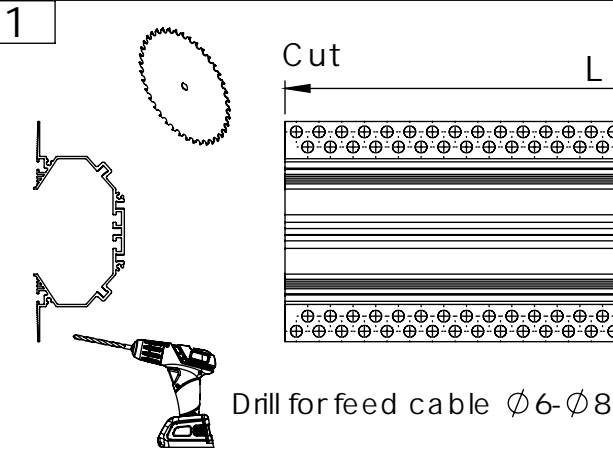

2 Linear and angle connection

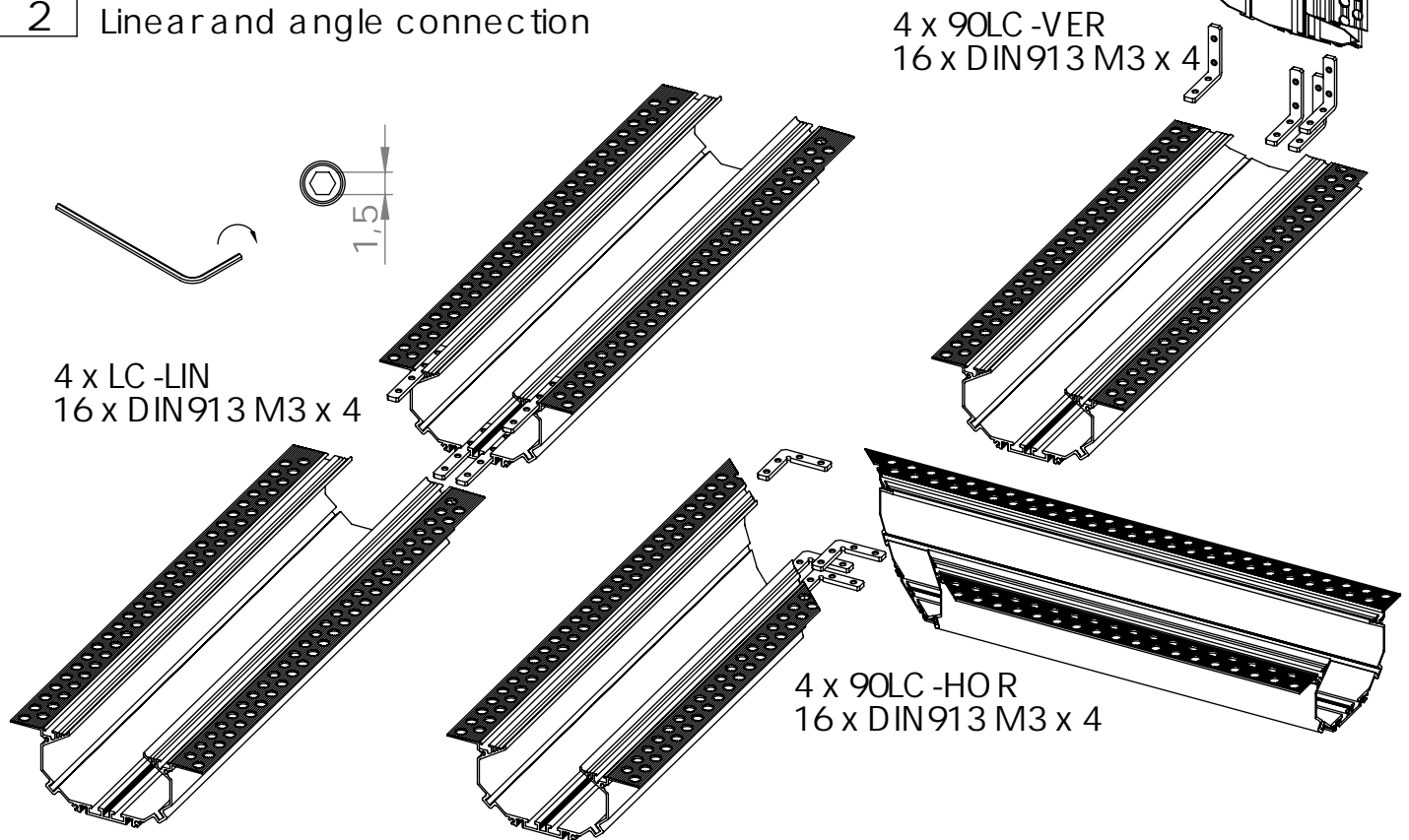

3 Screw the end cap

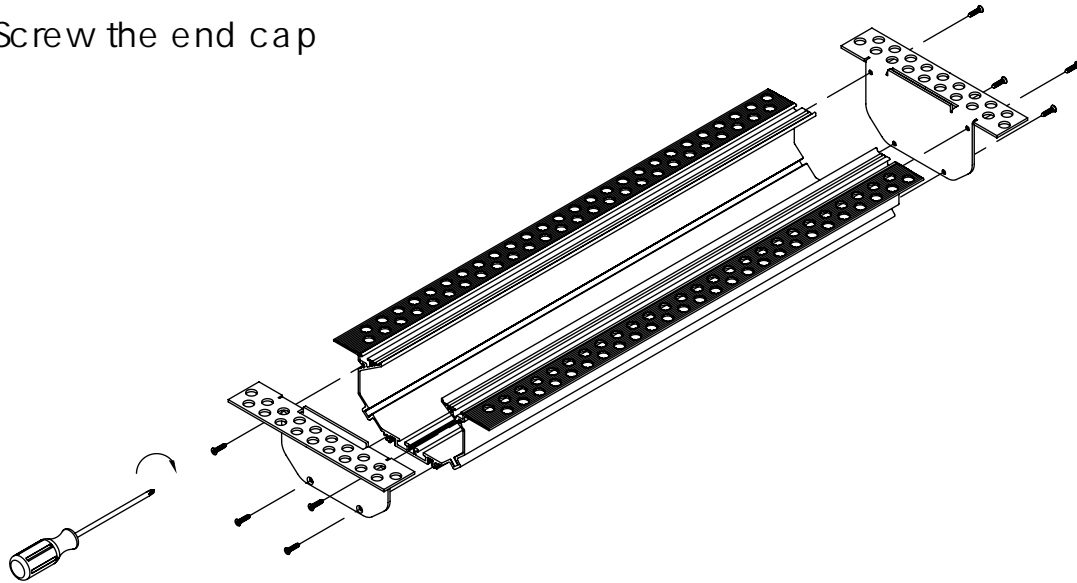

4 Cut out

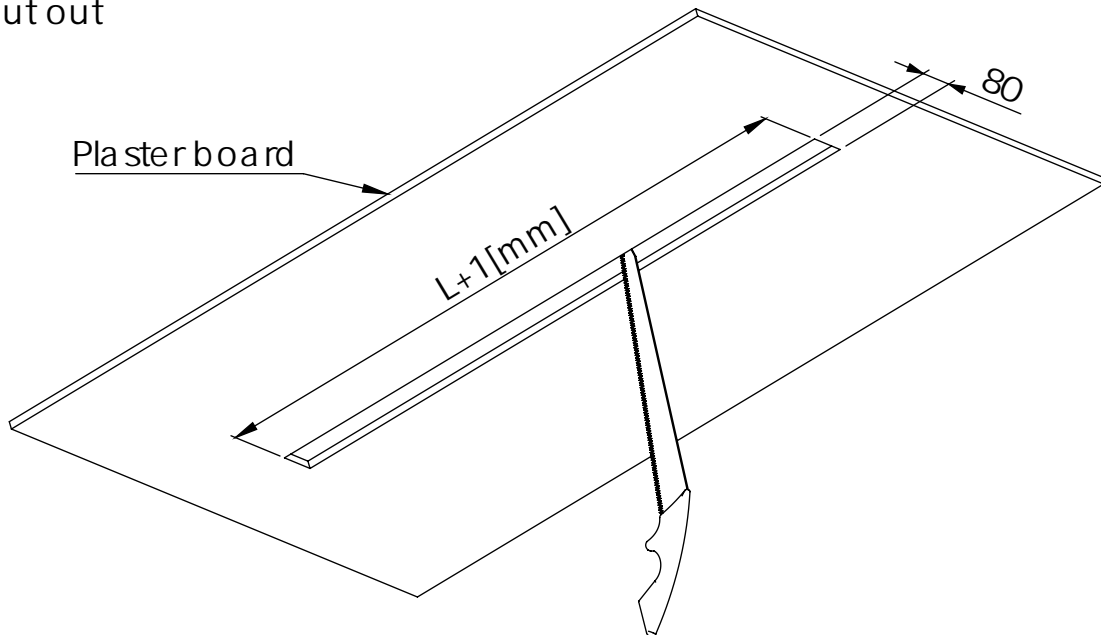

5 Screw the profile with plaster board using dedicated openings in the profile and end cap

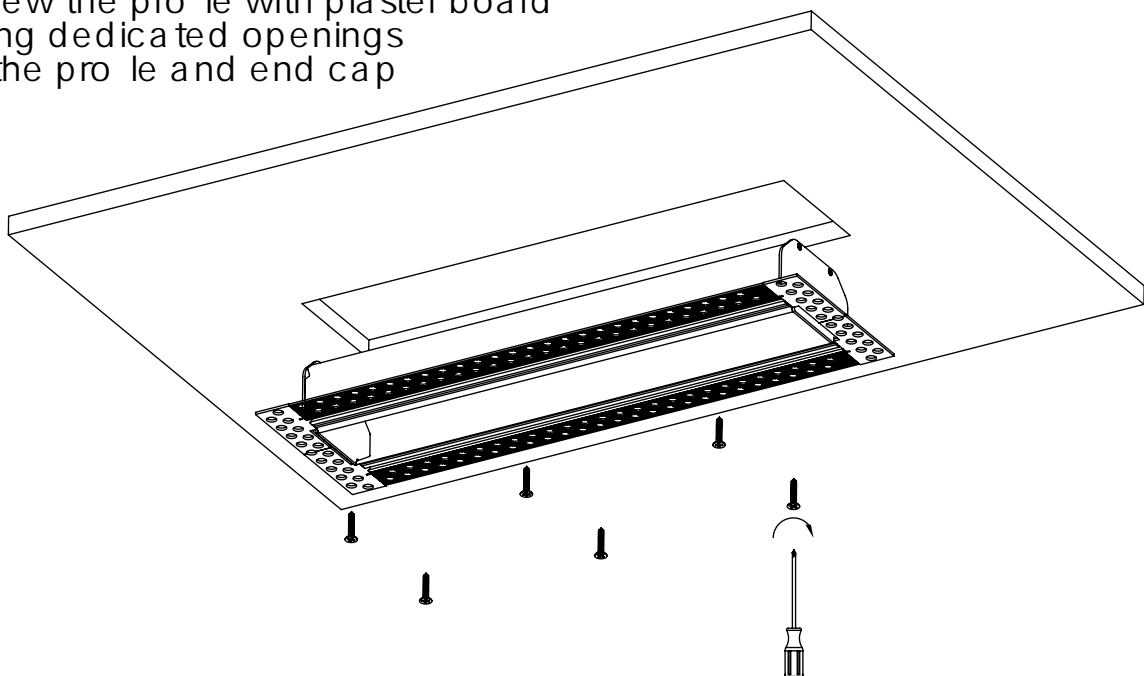

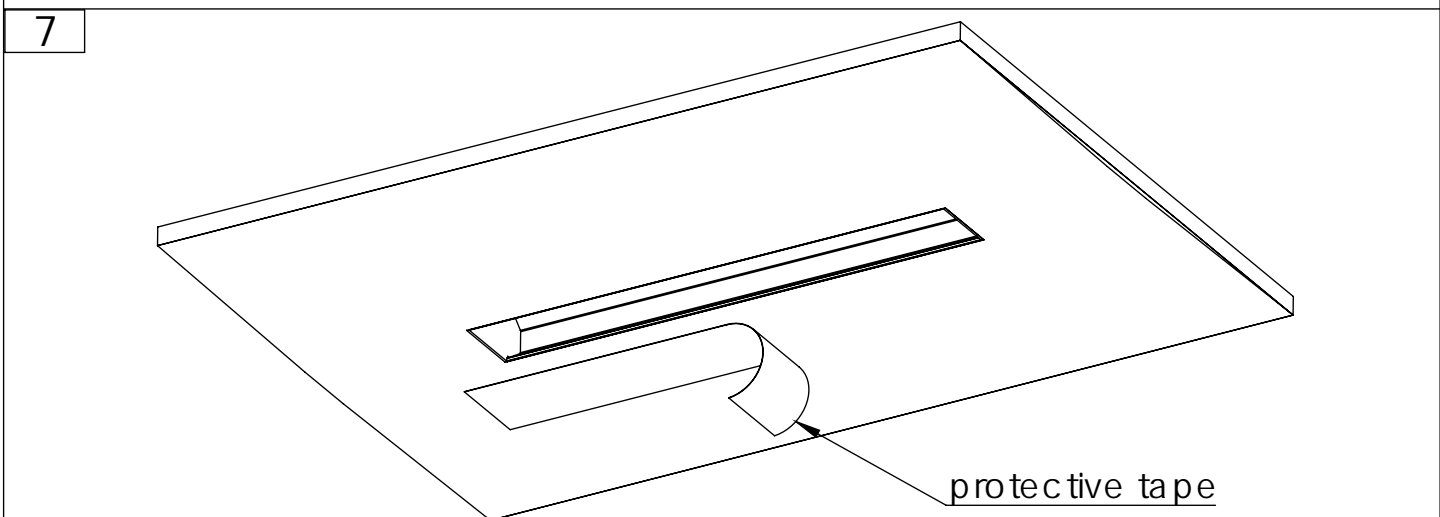
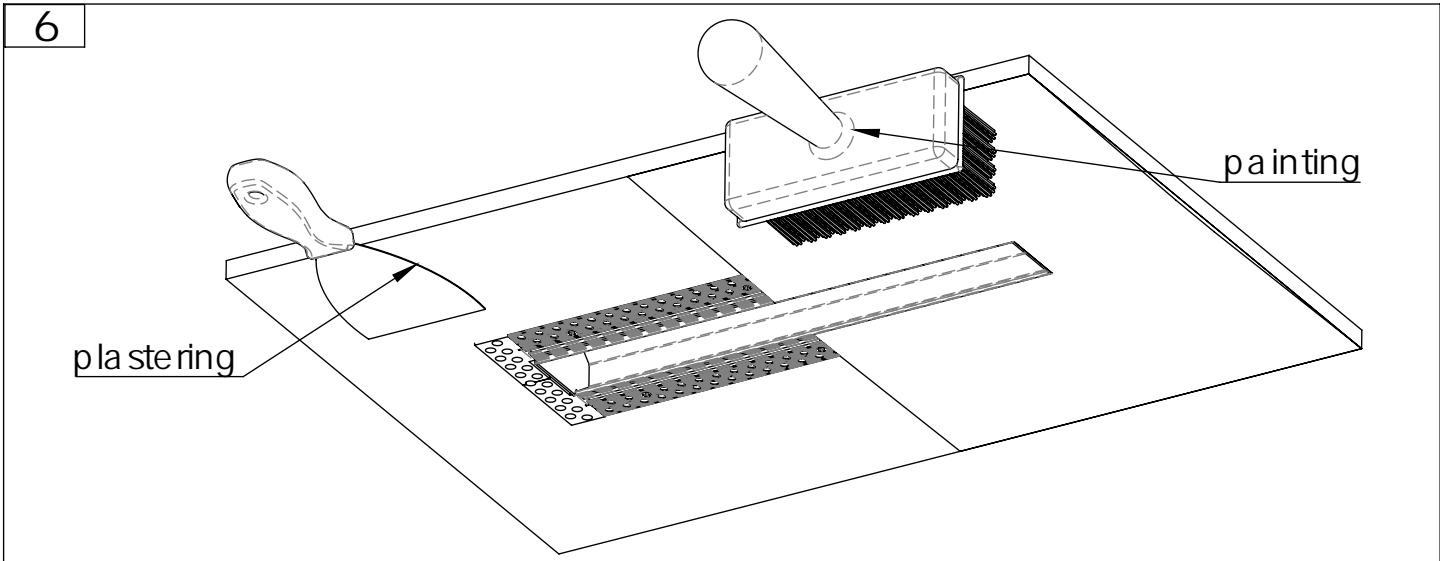

Remove the protective tape.
Clean the surface with alcohol to remove any dust or debris.

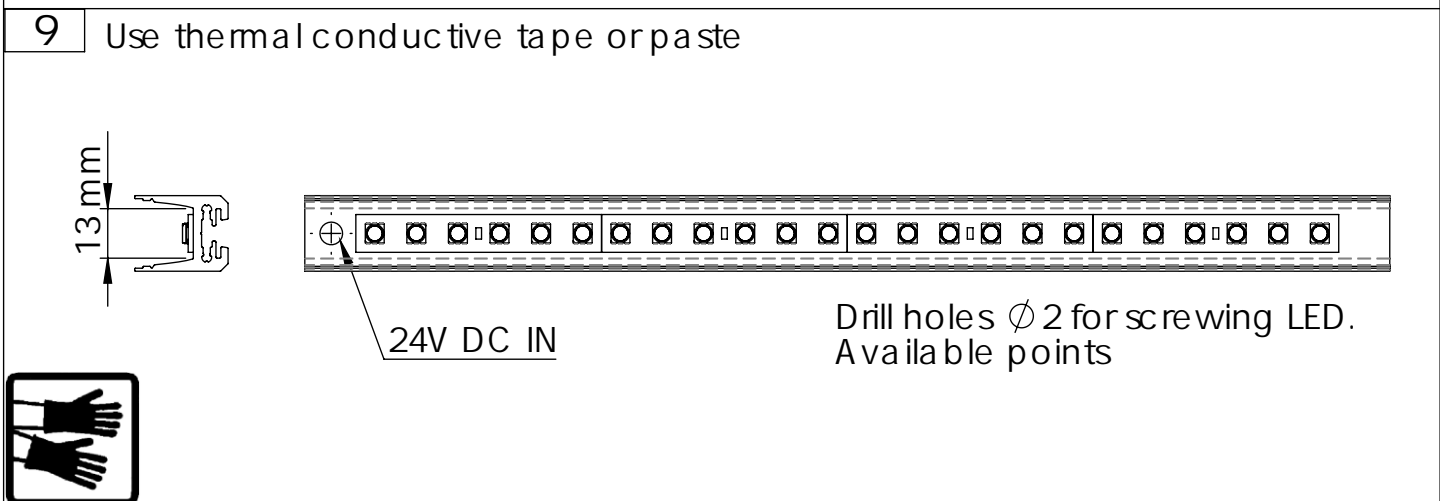
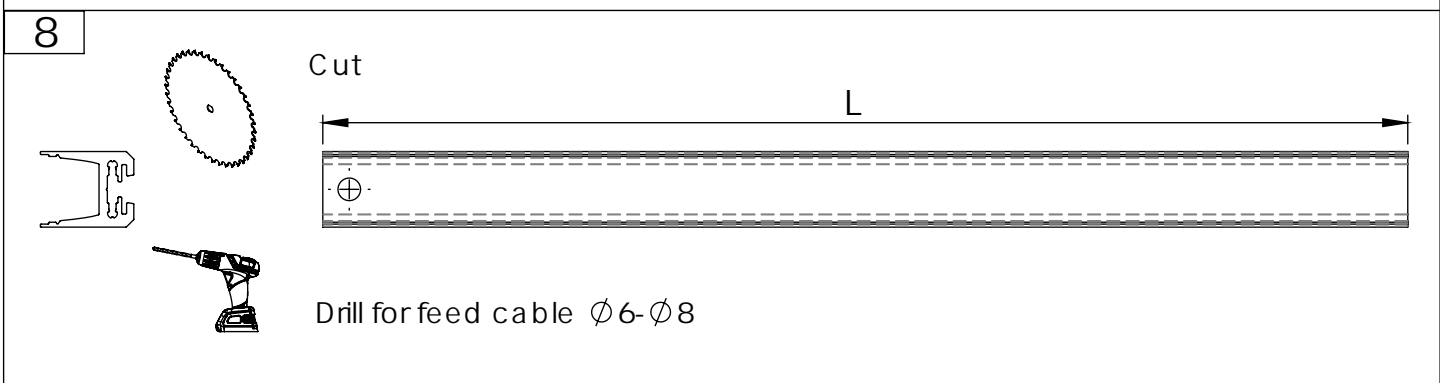

10 Screw the end cap

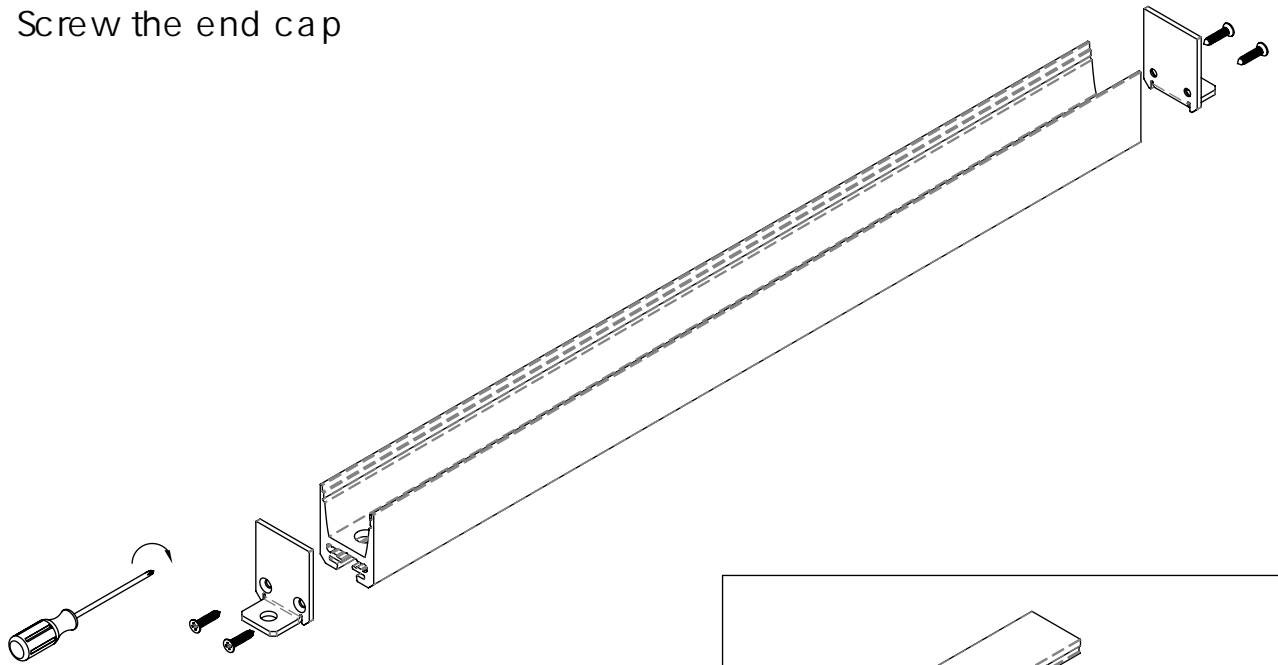

11 Click the diffuser into the profile

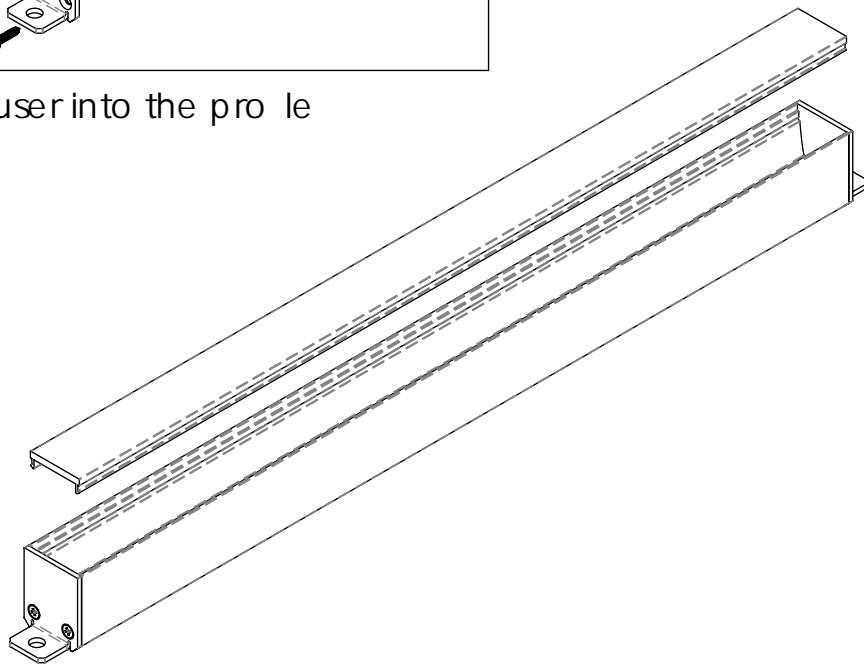

12 Screw the LED profile into the black base

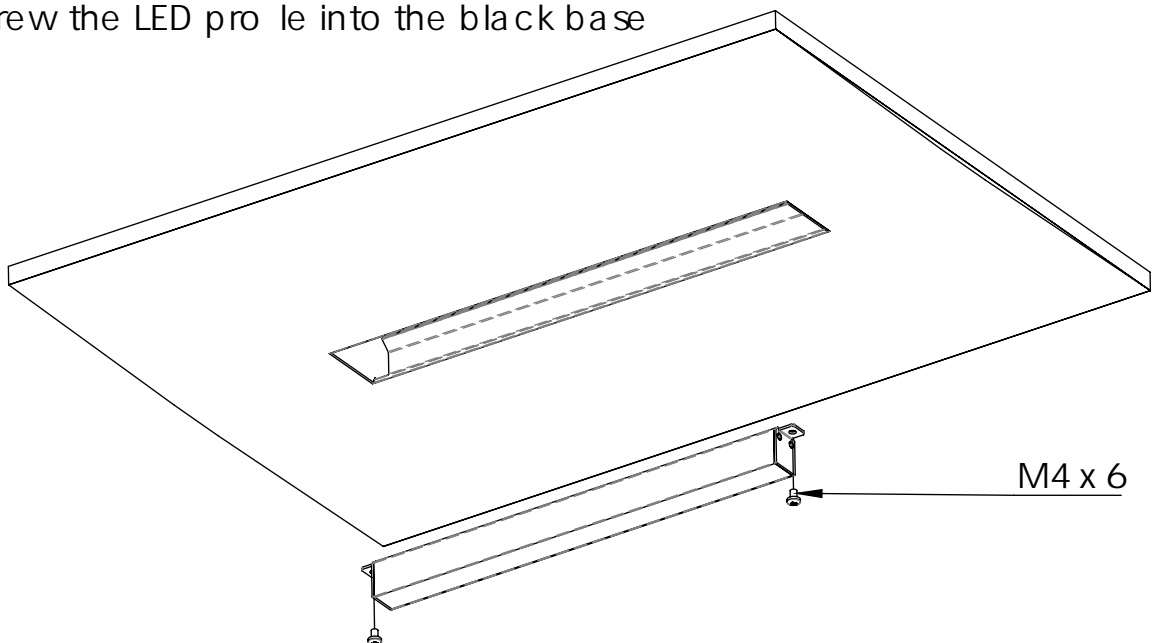

Connect power cable